

SIGN	REVISION	DATE	B Y
△1	Q-666, Renewal	130424	R. T
△2	Q-676	140623	R. T

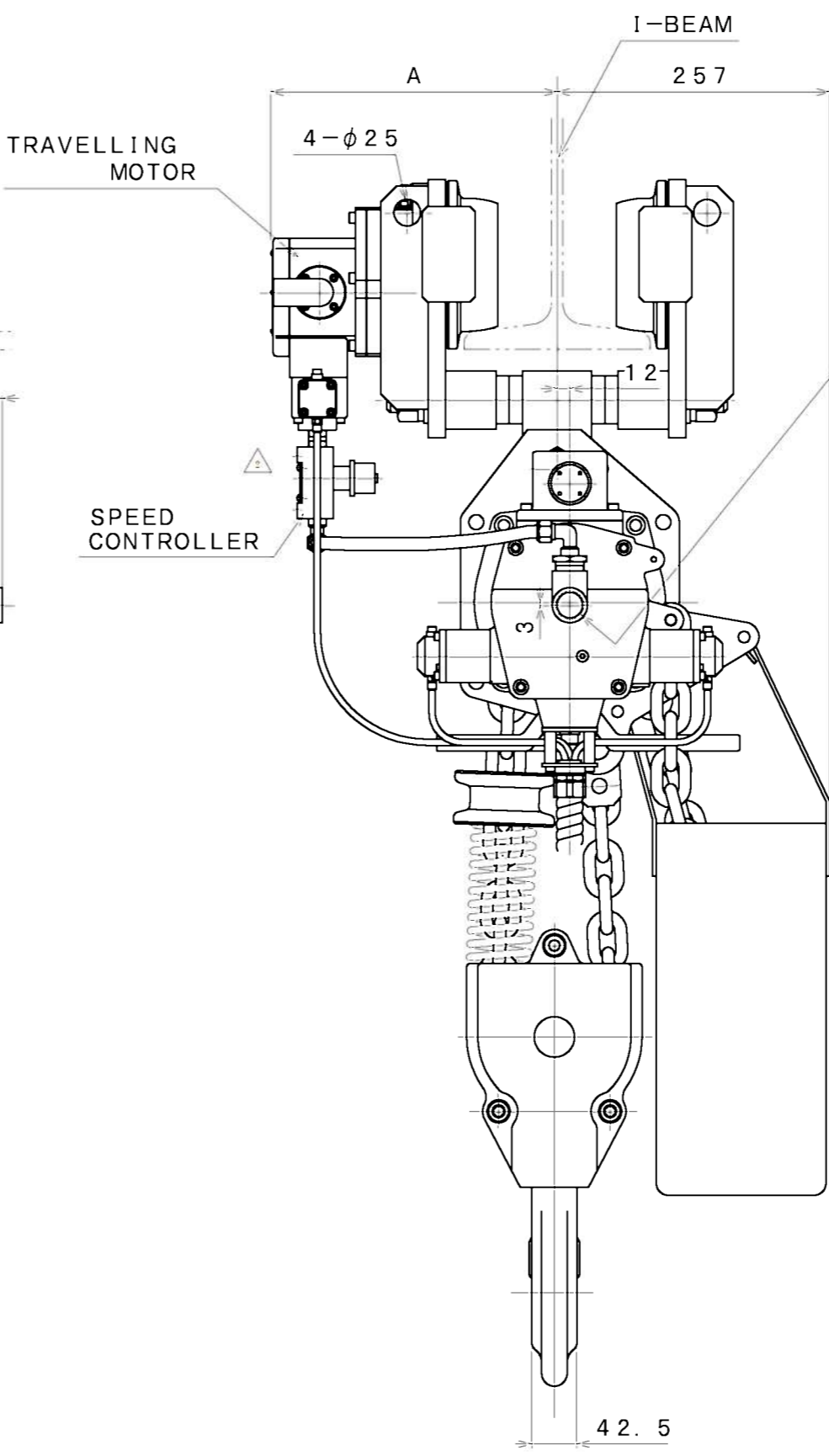
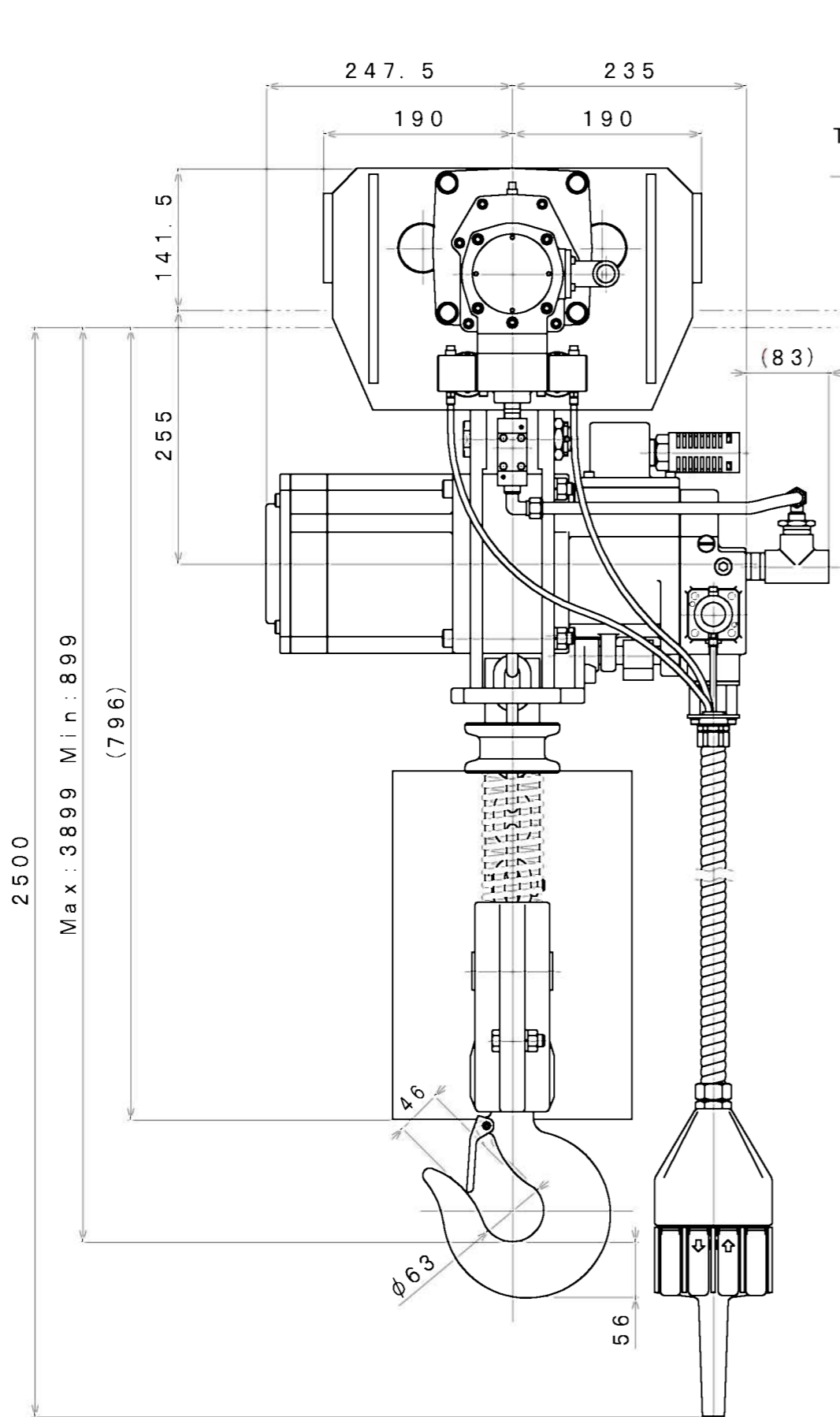

I-BEAM	A
125	245
150	257
175	270

**SPECIFICATION**

AIR PRESSURE	(MPa)	0.4	0.5	0.6
CAPACITY	(kg)	5000		
LIFTING SPEED	(m/min)	1.1	1.5	1.9
TRAVELING SPEED	(m/min)	10~15		
AIR CONSUMPTION	(m <sup>3</sup> /min (nor))	2.0	2.5	3.1
LIFT	(m)	3		
MASS	(kg)	about 176 △2		

APPROVED	CHECKED	REVIEWED	DRAWN	PARTICULARS	OUTLINE	DATE	OCT. 24. 2011
M. S	K. S		R. T	MODEL	VHX500LP-MR	NOTE	
					AIR HOIST		
SAN-EI SEIKI SEISAKUSHO CO., LTD.					DWG. NO.	E311-428	SCALE 1/6