

| SIGN | REVISION | DATE | B Y |
|------|----------|--------|------|
| ① | Renewal | 110516 | R. T |
| ② | Renewal | 150511 | A. T |

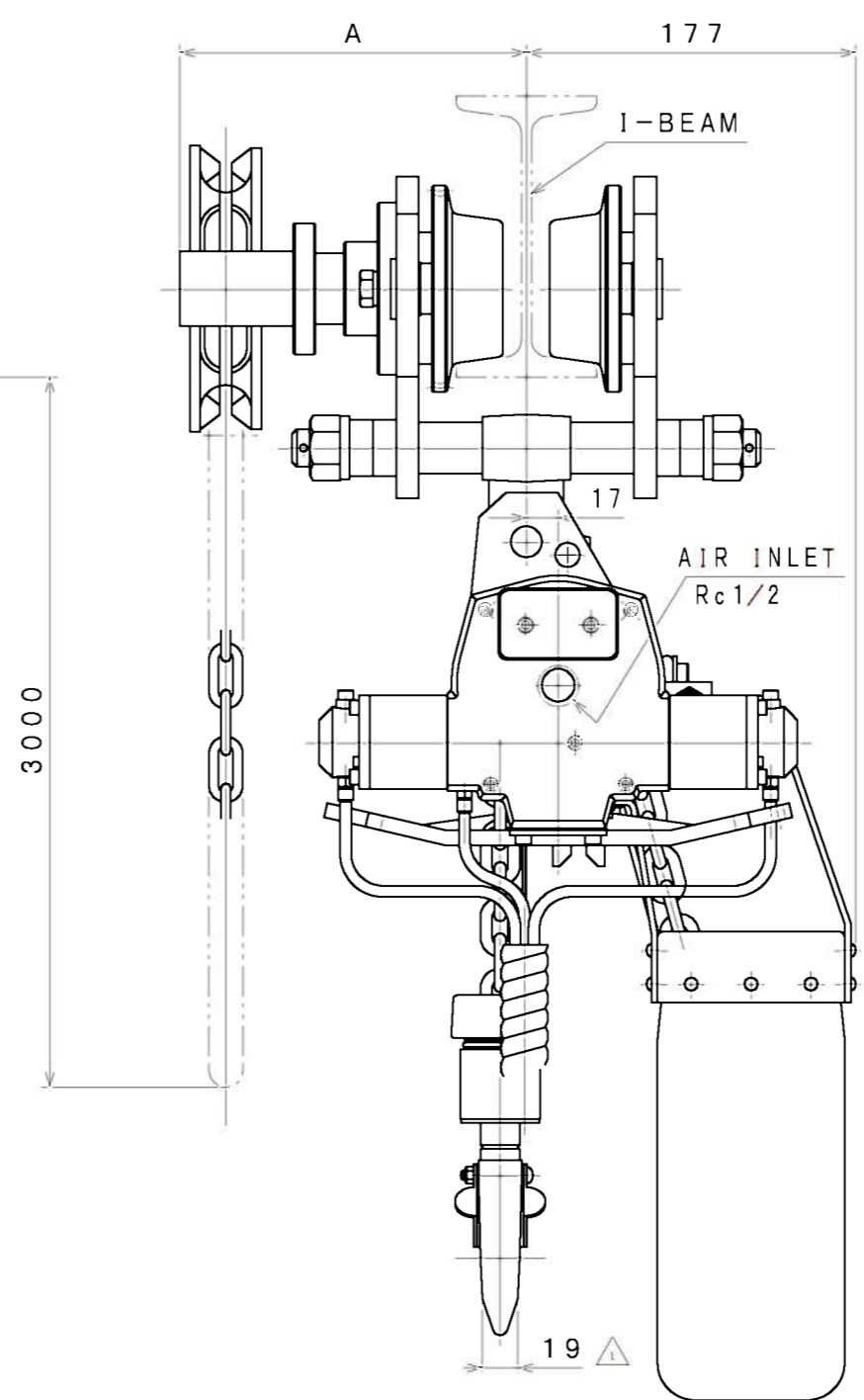
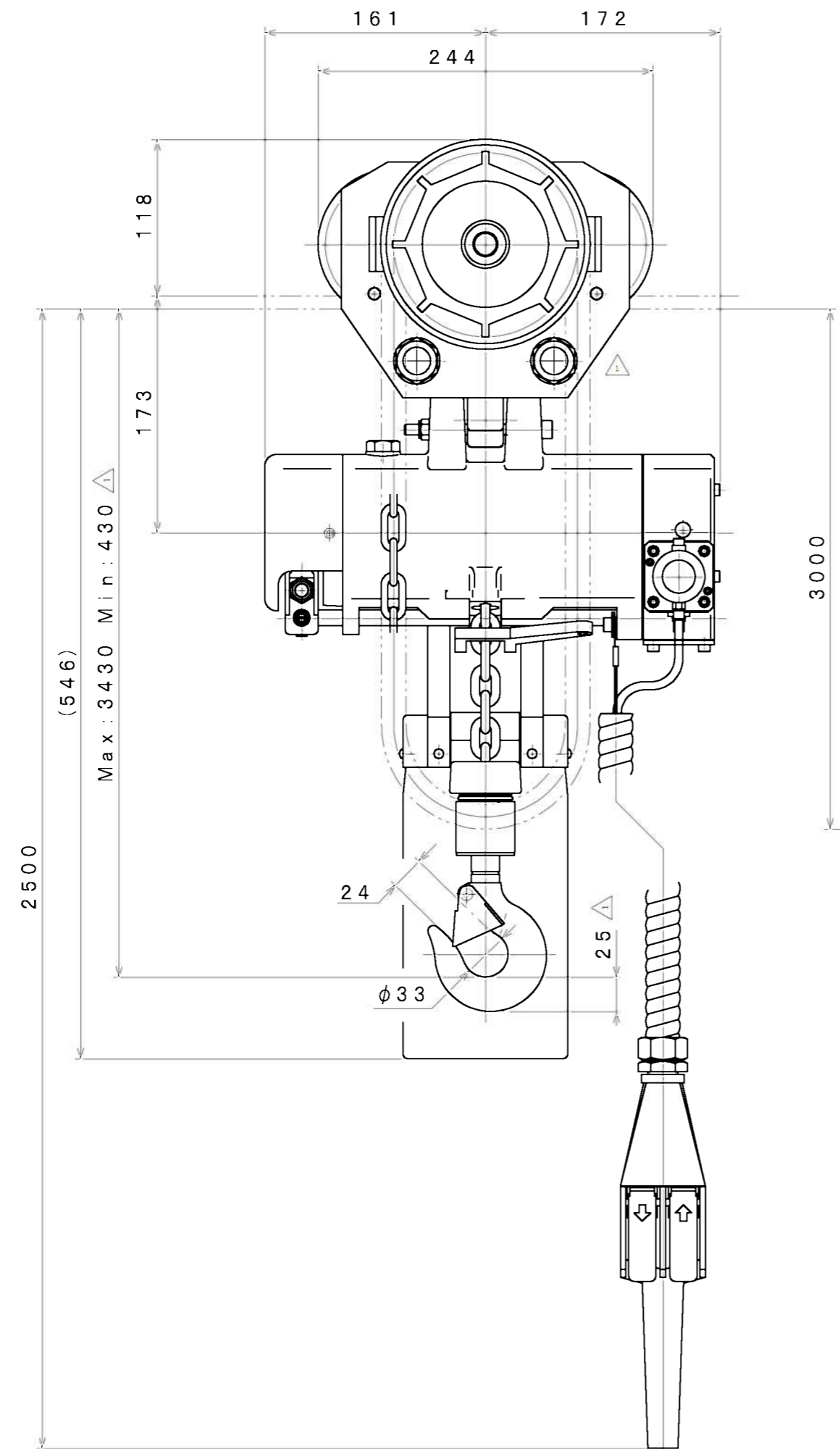

| I Beam wide size | A |
|------------------|-----|
| 75 | 185 |
| 100 | 198 |
| 125 | 210 |

SPECIFICATION

| | | | |
|---|------------|-----|-----|
| AIR PRESSURE (MPa) | 0.4 | 0.5 | 0.6 |
| CAPACITY (kg) | 500 | | |
| LIFTING SPEED (m/min) | 7 | 10 | 12 |
| AIR CONSUMPTION (m ³ /min (nor)) | 1.0 | 1.3 | 1.6 |
| LIFT (m) | 3 | | |
| MASS (kg) | about 46.5 | | |

| APPROVED | CHECKED | REVIEWED | DRAWN | PARTICULARS | OUTLINE DRAWING | DATE | Dec. 16. 2003 |
|-----------------------------------|---------|----------|-------|-------------|-----------------|----------|---------------|
| M. S | K. S | | R. T | MODEL | VLX50LP-GR | NOTE | |
| | | | | | AIR HOIST | Z96-058 | |
| SAN-EI SEIKI SEISAKUSHO CO., LTD. | | | | | DWG. NO. | E303-242 | SCALE 1/4 |