

SIGN	REVISION	DATE	B Y
△1	Renewal	111102	R. T
△2	Renewal	160407	W. S

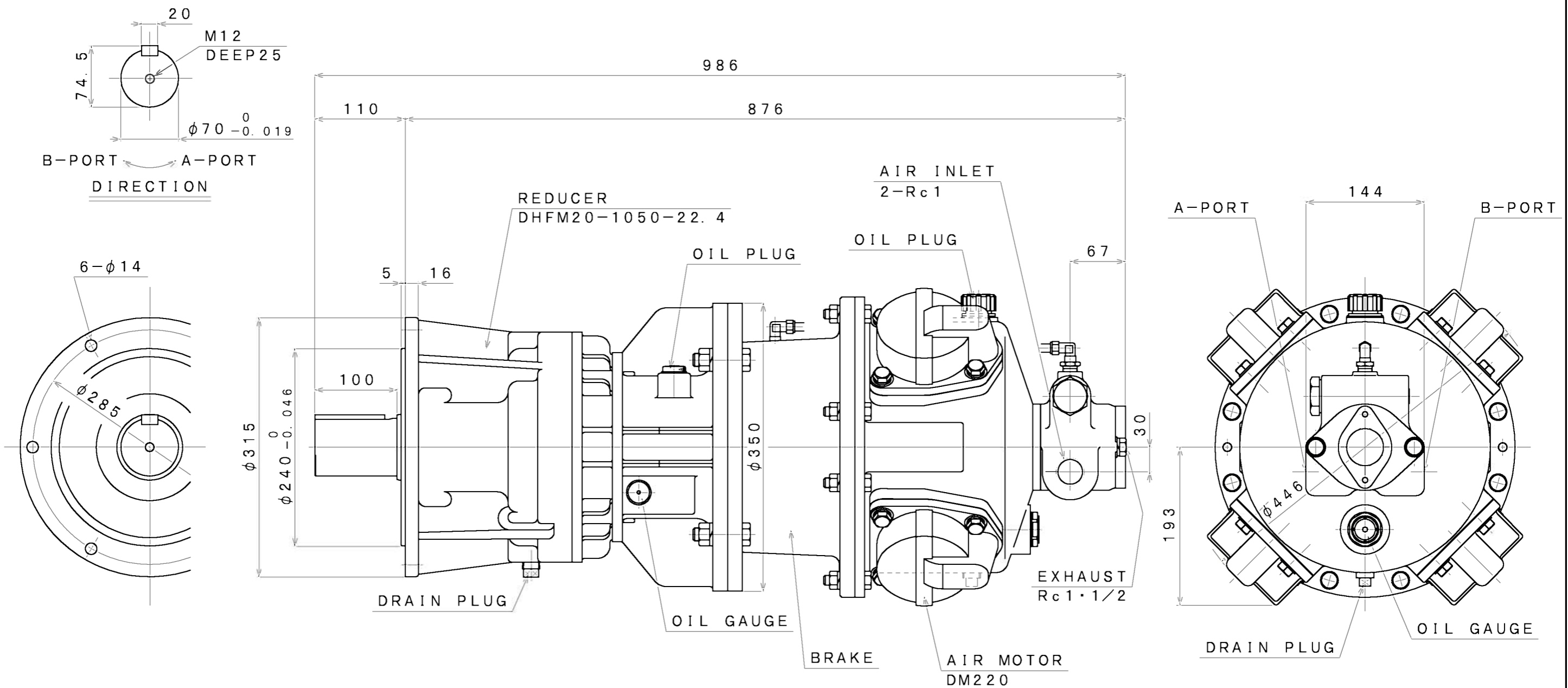

SPECIFICATION

AIR PRESSURE (MPa)	AT MAXIMUM OUTPUT				* ALLOWABLE SHAFT LOAD		LUBRICATING OIL		MASS (kg)
	OUTPUT (kW)	SPEED (rpm)	TORQUE (N·m)	AIR CONSUMPTION (m ³ /min (nor))	RADIAL (kN)	THRUST (kN)	AIR MOTOR	REDUCER	
0.6	6.81	32	2034	5.4	16.0	-	JIS K2213-1 Turbine Oil	JIS K2219 Gear Oil	about 192
0.5	5.74	30	1828	4.8			ISO VG32 (850cc)	ISO VG220 (1100cc)	
0.4	4.70	28	1602	4.1					

*:At Mid of Shaft

APPROVED	CHECKED	REVIEWED	DRAWN	PARTICULARS	OUTLINE DRAWING	DATE	OCT. 12. 2010
M. M	M. S	K. S	W. S	MODEL	DM220B-F-1050-22.4	NOTE	
SAN-EI SEIKI SEISAKUSHO CO., LTD.					DWG. NO.	E310-580	SCALE 1/5