

SIGN	REVISION	DATE	B Y
△1	Renewal	111101	R. T
△2	Renewal, Correction	160406	W. S

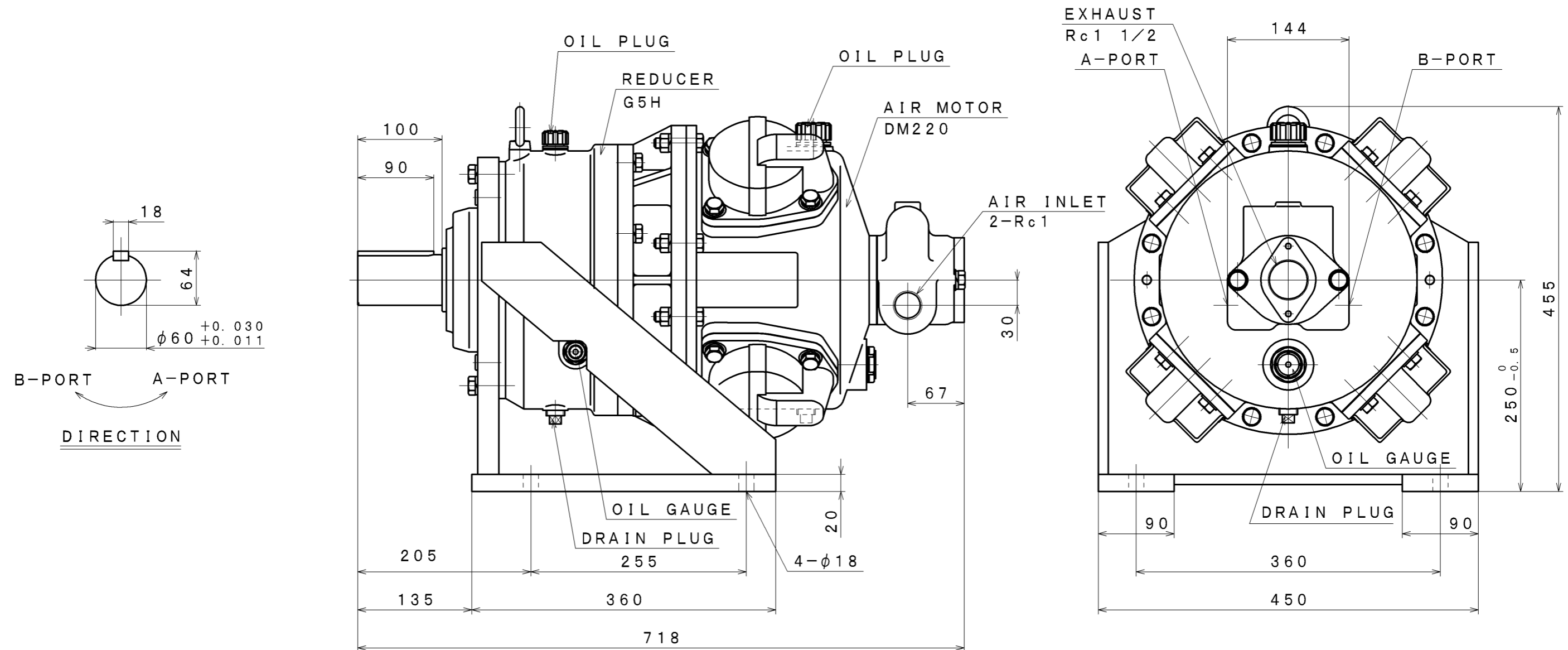

SPECIFICATION

AIR PRESSURE	AT MAXIMUM OUTPUT				※ ALLOWABLE SHAFT LOAD		LUBRICATING OIL		MASS
	OUTPUT	SPEED	TORQUE	AIR CONSUMPTION	RADIAL	THRUST	AIR MOTOR	REDUCER	
(MPa)	(kW)	(rpm)	(N·m)	(m ³ /min (nor))	(kN)	(kN)	JIS K2213-1 Turbine Oil	JIS K2219 Gear Oil	(kg)
0.6	6.75	125	516	5.4	7.3	1.4	ISO VG32 (850cc)	ISO VG220 (600cc)	about 204
0.5	△5.33	110	△463	4.8					
0.4	△4.24	100	△405	4.1					

※: At Mid of Shaft

APPROVED	CHECKED	REVIEWED	DRAWN	PARTICULARS	OUTLINE DRAWING	DATE	JAN. 22. 2010
M. M		W. S		MODEL	DM220G5H6B	NOTE	
					AIR MOTOR	Z00-014	
SAN-EI SEIKI SEISAKUSHO CO., LTD.					DWG. NO.	E310-061	SCALE 1/5