

SIGN	REVISION	DATE	B Y
△1	Renewal	100301	W. S
△2	Correction	100910	M. S
△3	Renewal	111028	R. T
△4	Renewal	130523	W. S

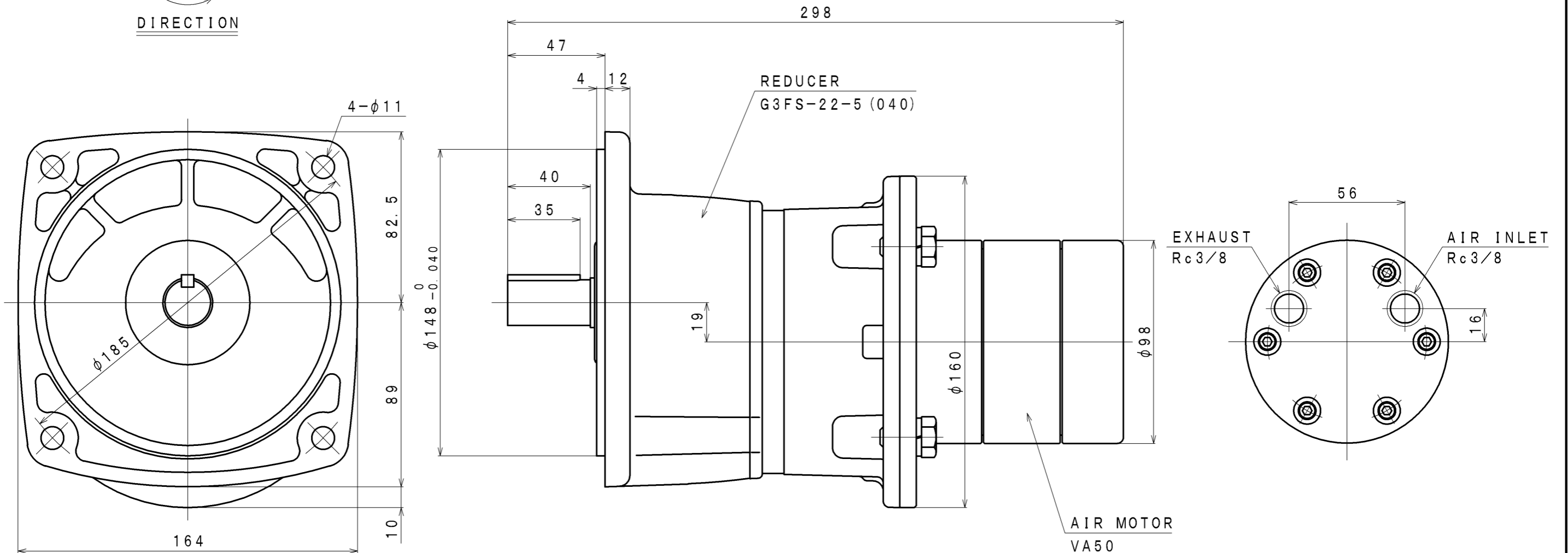
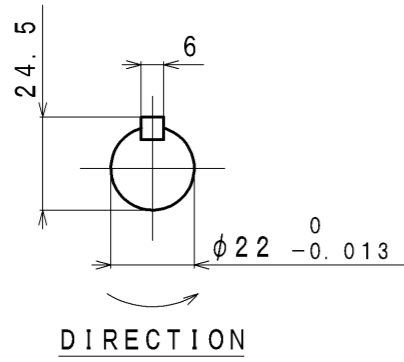

SPECIFICATION

AIR PRESSURE (MPa)	AT MAXIMUM OUTPUT				※ ALLOWABLE SHAFT LOAD		LUBRICATING OIL	MASS (kg)
	OUTPUT (kW)	SPEED (rpm)	TORQUE (N·m)	AIR CONSUMPTION (m ³ /min (nor))	RADIAL (N)	THRUST (N)	AIR MOTOR (Line Oiler)	
0.6	0.39	392	9.5	0.79	392	245	△ JIS K2213-1 Turbine Oil ISO VG32 (Line Oiler Dripping Quantity: 2~3 drop/min)	△ about 10.6
0.5	0.32	360	8.5	0.68				
0.4	0.25	324	7.5	0.56				

※: At Mid of Shaft

APPROVED	CHECKED	REVIEWED	DRAWN	PARTICULARS	OUTLINE DRAWING	DATE	JAN. 24. 2009
M. M		W. S		MODEL	VA50R-F005	NOTE	
					AIR MOTOR	Z96-092	
SAN-EI SEIKI SEISAKUSHO CO., LTD.				DWG. NO.	E308-225	SCALE	1/2