

SIGN	REVISION	DATE	B Y
△1	Renewal	111031	R. T
△2	Renewal	160404	W. S

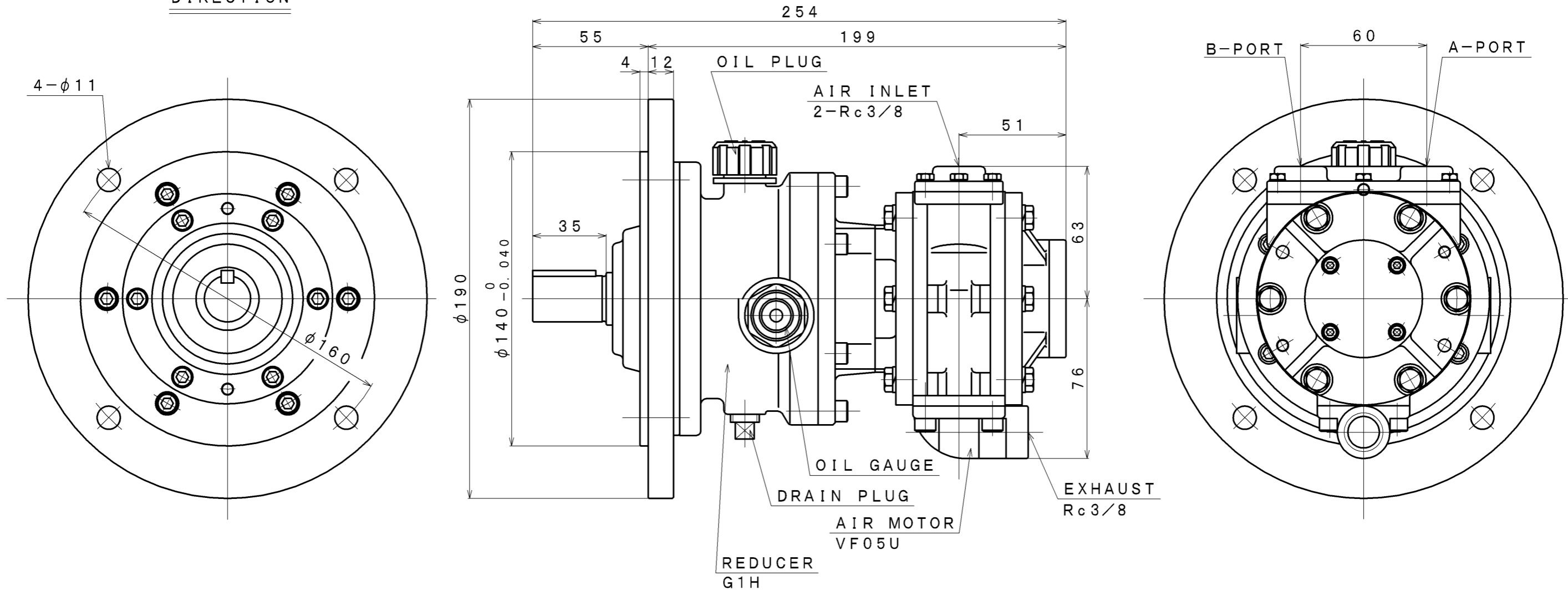
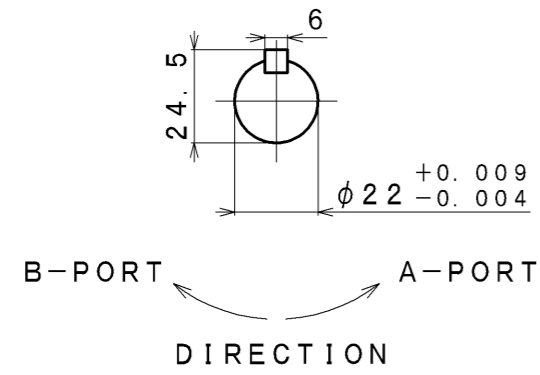

SPECIFICATION

AIR PRESSURE	AT MAXIMUM OUTPUT				* ALLOWABLE SHAFT LOAD		LUBRICATING OIL		MASS
	OUTPUT	SPEED	TORQUE	AIR CONSUMPTION	RADIAL	THRUST	AIR MOTOR	REDUCER	
(MPa)	(kW)	(rpm)	(N·m)	(m ³ /min (nor))	(kN)	(kN)	△ JIS K2213-1 Turbine Oil ISO VG32 Line Oiler Dripping Quantity: 3~4 drop/min	JIS K2219 Gear Oil ISO VG220 (60 cc)	(kg)
0.6	0.85	871	9.3	1.3	0.8	0.2			about 11.6
0.5	0.72	813	8.5	1.1					
0.4	0.57	755	7.2	0.9					

*:At Mid of Shaft

APPROVED	CHECKED	REVIEWED	DRAWN	PARTICULARS	OUTLINE DRAWING	DATE	FEB. 05. 2010
M. M		W. S		MODEL	VF05U-G1H4F	NOTE	
					AIR MOTOR	Z06-042	
SAN-EI SEIKI SEISAKUSHO CO., LTD.					DWG. NO.	E310-091	SCALE 1/2