

SIGN	REVISION	DATE	B Y
△1	Renewal	111031	R. T
△2	Renewal	160405	W. S

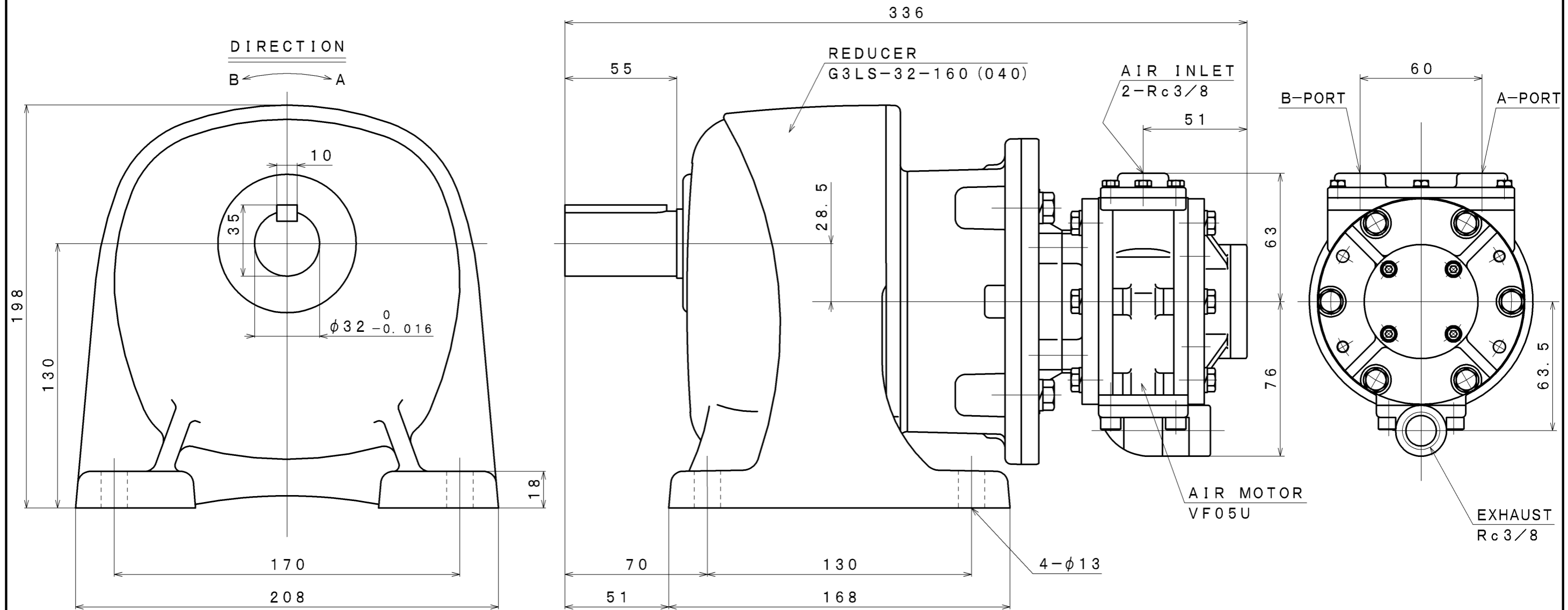

**SPECIFICATION**

AIR PRESSURE	AT MAXIMUM OUTPUT				※ ALLOWABLE SHAFT LOAD		LUBRICATING OIL	MASS
	OUTPUT	SPEED	TORQUE	AIR CONSUMPTION	RADIAL	THRUST		
(MPa)	(kW)	(rpm)	(N·m)	(m <sup>3</sup> /min (nor))	(N)	(N)	△ JIS K2213-1 Turbine Oil ISO VG32 Line Oiler Dripping Quantity: 3~4 drop/min	(kg)
0.6	0.76	19	384	1.3	5880	834		about 14.7
0.5	0.66	18	350	1.1				
0.4	0.50	16	296	0.9				

※: At Mid of Shaft

APPROVED	CHECKED	REVIEWED	DRAWN	PARTICULARS	OUTLINE DRAWING	DATE	AUG. 31. 2010
M. S		K. S	W. S	MODEL	VF05U-L32-160	NOTE	
					AIR MOTOR	Z06-030	
SAN-EI SEIKI SEISAKUSHO CO., LTD.					DWG. NO.	E310-304	SCALE 1/2