

SIGN	REVISION	DATE	BY
△1	CORRECTION	091112	R. T
△2	RENEWAL	111031	R. T
△3	RENEWAL	120413	R. T
△4	Renewal	160404	W. S

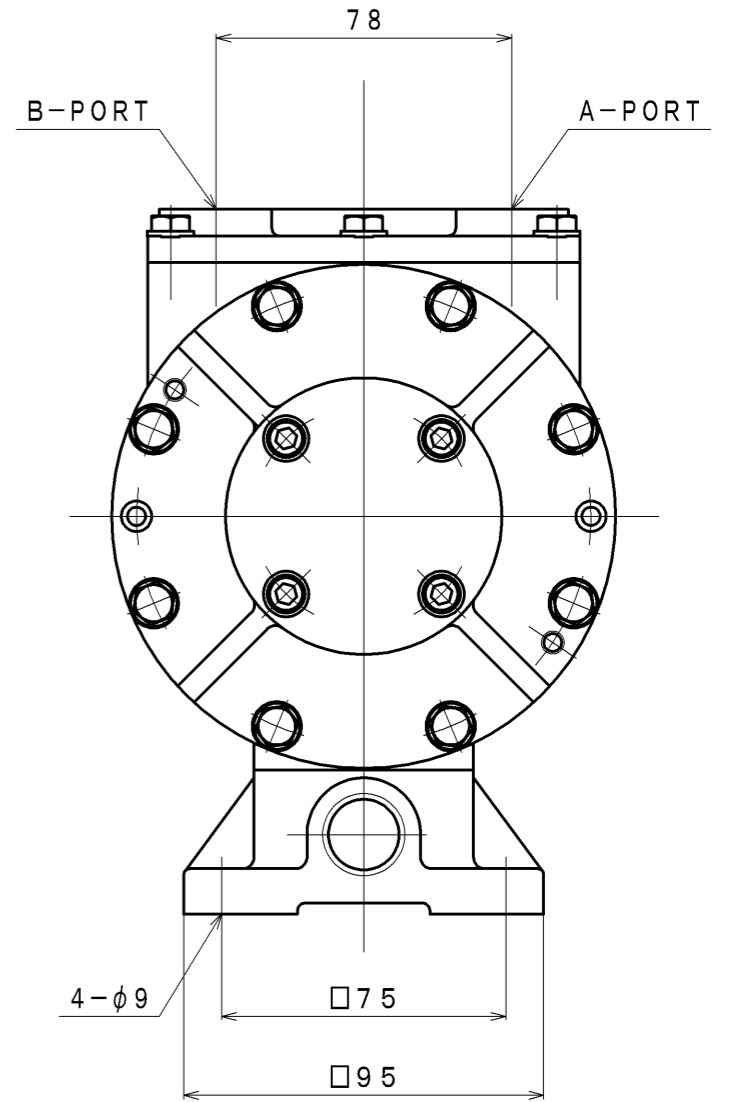
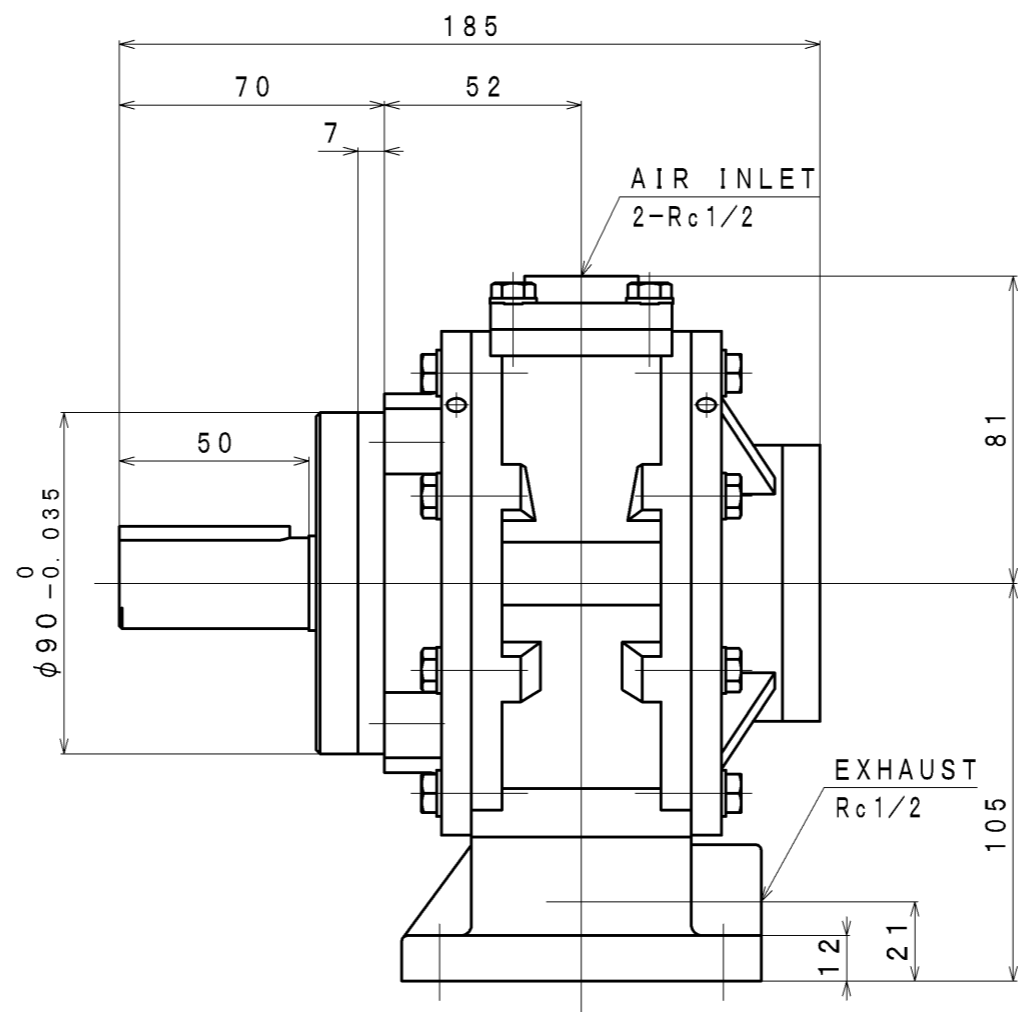
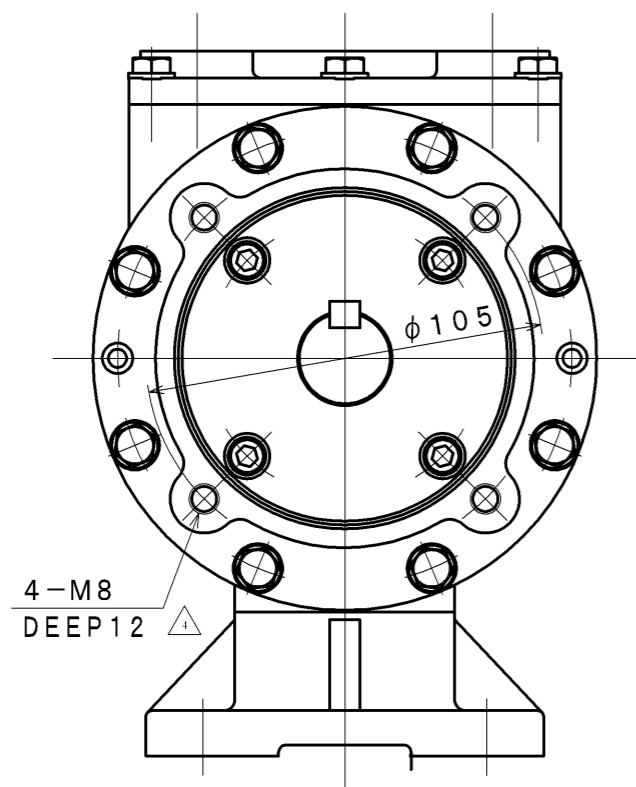
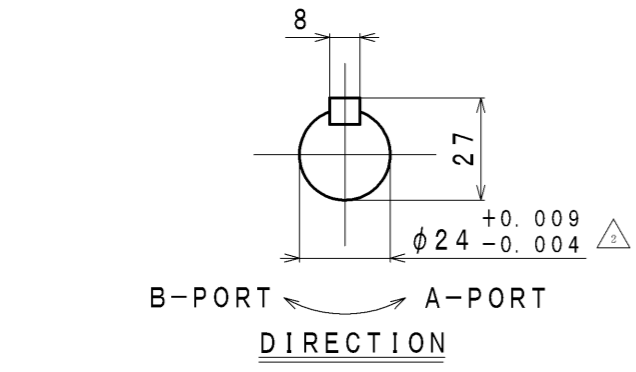

SPECIFICATION

AIR PRESSURE (MPa)	AT MAXIMUM OUTPUT				* ALLOWABLE SHAFT LOAD		LUBRICATING OIL	MASS (kg)
	OUTPUT (kW)	SPEED (rpm)	TORQUE (N·m)	AIR CONSUMPTION (m ³ /min (nor))	RADIAL (kN)	THRUST (kN)	AIR MOTOR (Line Oiler)	
0.6	2.04	2500	7.80	2.5	0.83	0.20	△ JIS K2213-1 Turbine Oil ISO VG32 (Line Oiler Dripping Quantity: 7~8 drop/min)	9.0
0.5	1.71	2300	7.10	2.1 △				
0.4	1.32	2100	6.00	1.8				

*: At Mid of Shaft

APPROVED	CHECKED	REVIEWED	DRAWN	PARTICULARS	OUTLINE DRAWING	DATE	Nov. 07. 2005
M. S	K. S		R. T	MODEL	VF20-UBD1	NOTE	
					AIR MOTOR	Z05-039 △	
SAN-EI SEIKI SEISAKUSYO CO., LTD.				DWG. NO.	E305-209 △	SCALE	1/2