

SIGN	REVISION	DATE	B Y
△1	Renewal	111031	R. T
△2	Renewal	160404	W. S

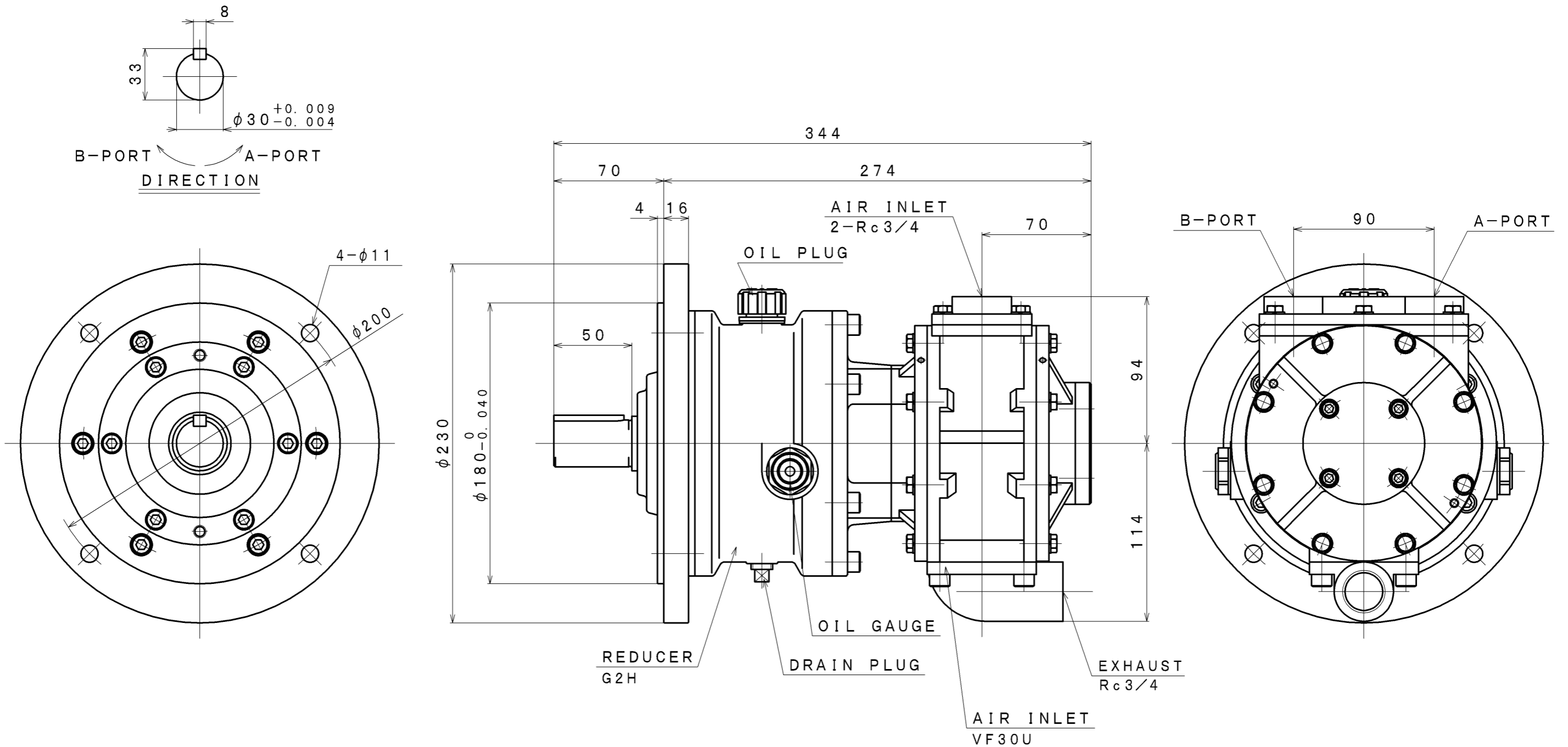

SPECIFICATION

AIR PRESSURE	AT MAXIMUM OUTPUT				* ALLOWABLE SHAFT LOAD		LUBRICATING OIL		MASS
	OUTPUT	SPEED	TORQUE	AIR CONSUMPTION	RADIAL	THRUST	AIR MOTOR	REDUCER	
(MPa)	(kW)	(rpm)	(N·m)	(m ³ /min (nor))	(kN)	(kN)	△ JIS K2213-1 Turbine Oil ISO VG32 Line Oiler Dripping Quantity: 10~12drop/min	JIS K2219 Gear Oil ISO VG220 (130cc)	(kg)
0.6	2.41	400	57.5	3.1	1.9	0.5			about 31
0.5	1.99	364	52.3	2.6					
0.4	1.52	327	44.4	2.0					

*: At Mid of Shaft

APPROVED	CHECKED	REVIEWED	DRAWN	PARTICULARS	OUTLINE DRAWING	DATE	FEB. 15. 2010
M. M		W. S		MODEL	VF30U-G2H6F	NOTE	
					AIR MOTOR	Z06-048	
SAN-EI SEIKI SEISAKUSHO CO., LTD.					DWG. NO.	E310-111	SCALE 3/8