

SIGN	REVISION	DATE	B Y
△1	Renewal	111122	R. T
△2	Renewal	160405	W. S

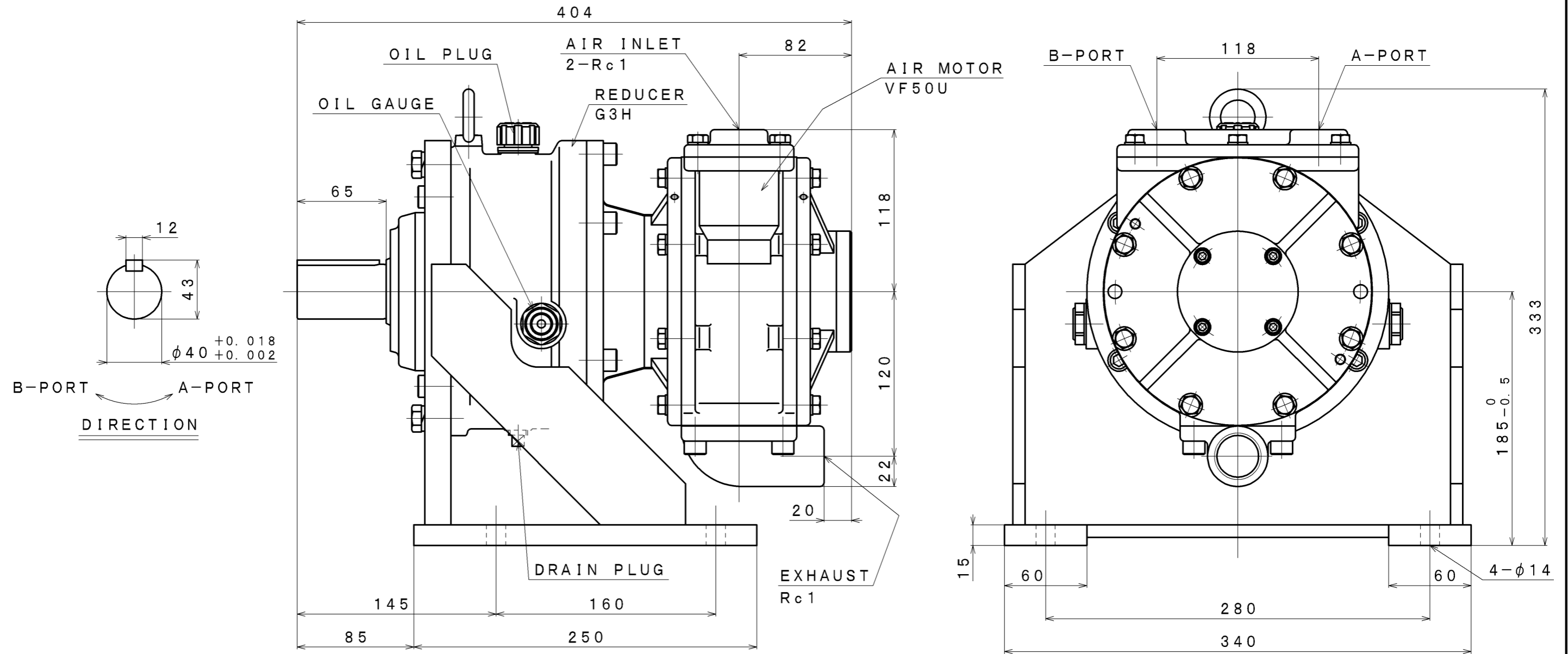

SPECIFICATION

AIR PRESSURE (MPa)	AT MAXIMUM OUTPUT				* ALLOWABLE SHAFT LOAD		LUBRICATING OIL		MASS (kg)
	OUTPUT (kW)	SPEED (rpm)	TORQUE (N·m)	AIR CONSUMPTION (m ³ /min (nor))	RADIAL (kN)	THRUST (kN)	AIR MOTOR	REDUCER	
0.6	4.93	258	182.6	6.2	△ 2.8	0.5	△ JIS K2213-1 Turbine Oil ISO VG32	JIS K2219 Gear Oil ISO VG220 (150cc)	about 63
0.5	4.03	232	165.7	5.4			Line Oiler Dripping Quantity: 15~20drop/min		
0.4	3.04	206	140.6	4.5					

*: At Mid of Shaft

APPROVED	CHECKED	REVIEWED	DRAWN	PARTICULARS	OUTLINE DRAWING	DATE	FEB. 16. 2010
M. M		W. S		MODEL	VF50U-G3H8B	NOTE	
					AIR MOTOR	Z06-051	
SAN-EI SEIKI SEISAKUSHO CO., LTD.					DWG. NO.	E310-119	SCALE 1/3