

SIGN	REVISION	DATE	BY
△1	Renewal	111031	R. T
△2	Renewal	120413	R. T
△3	Renewal	160404	W. S

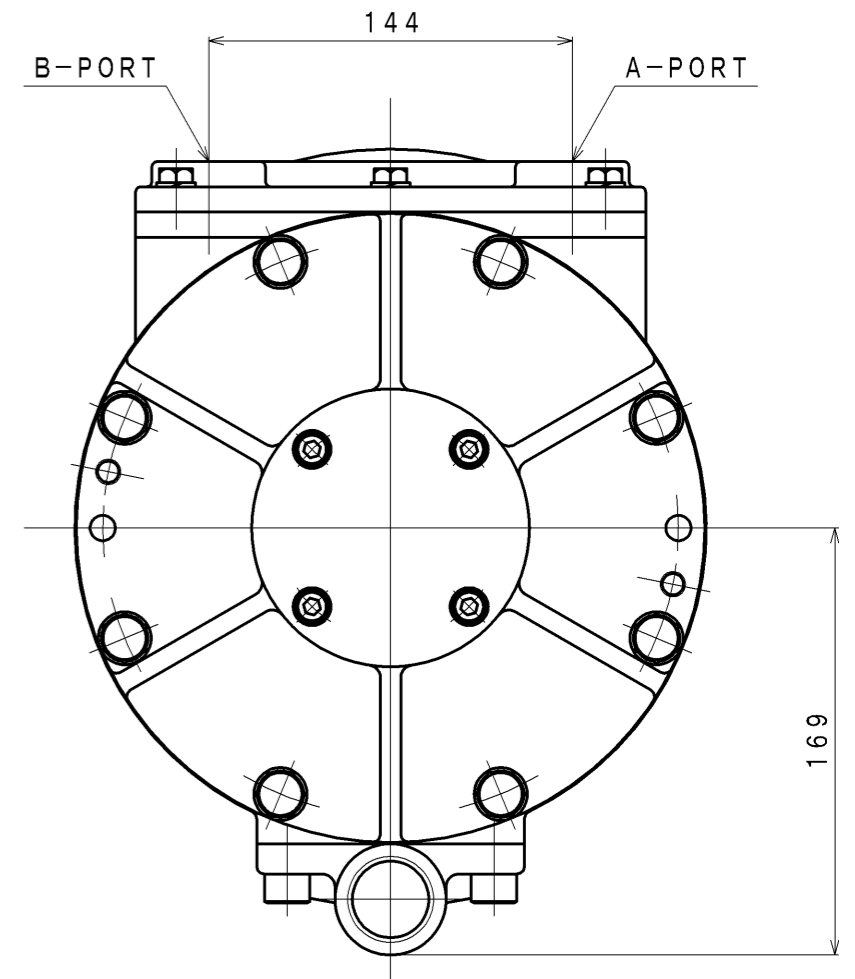
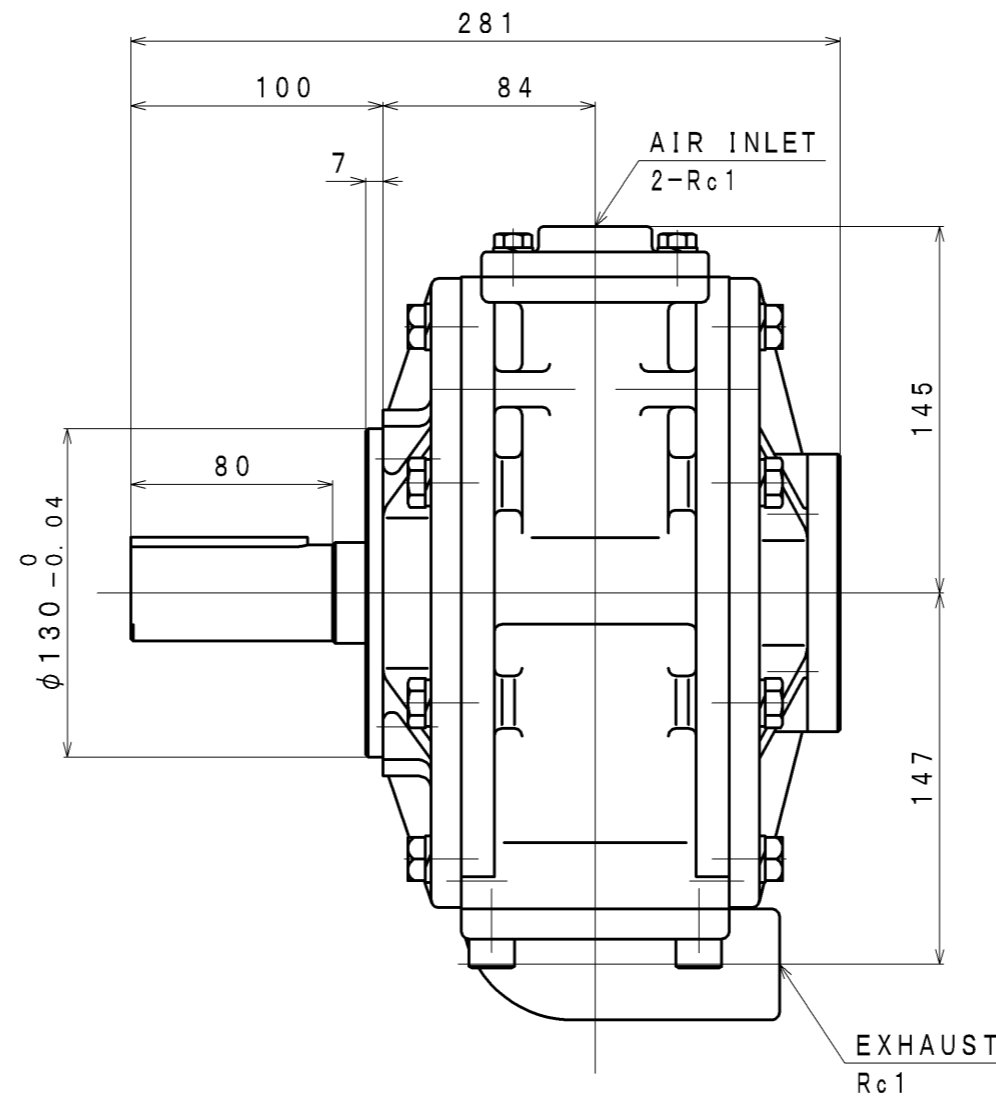
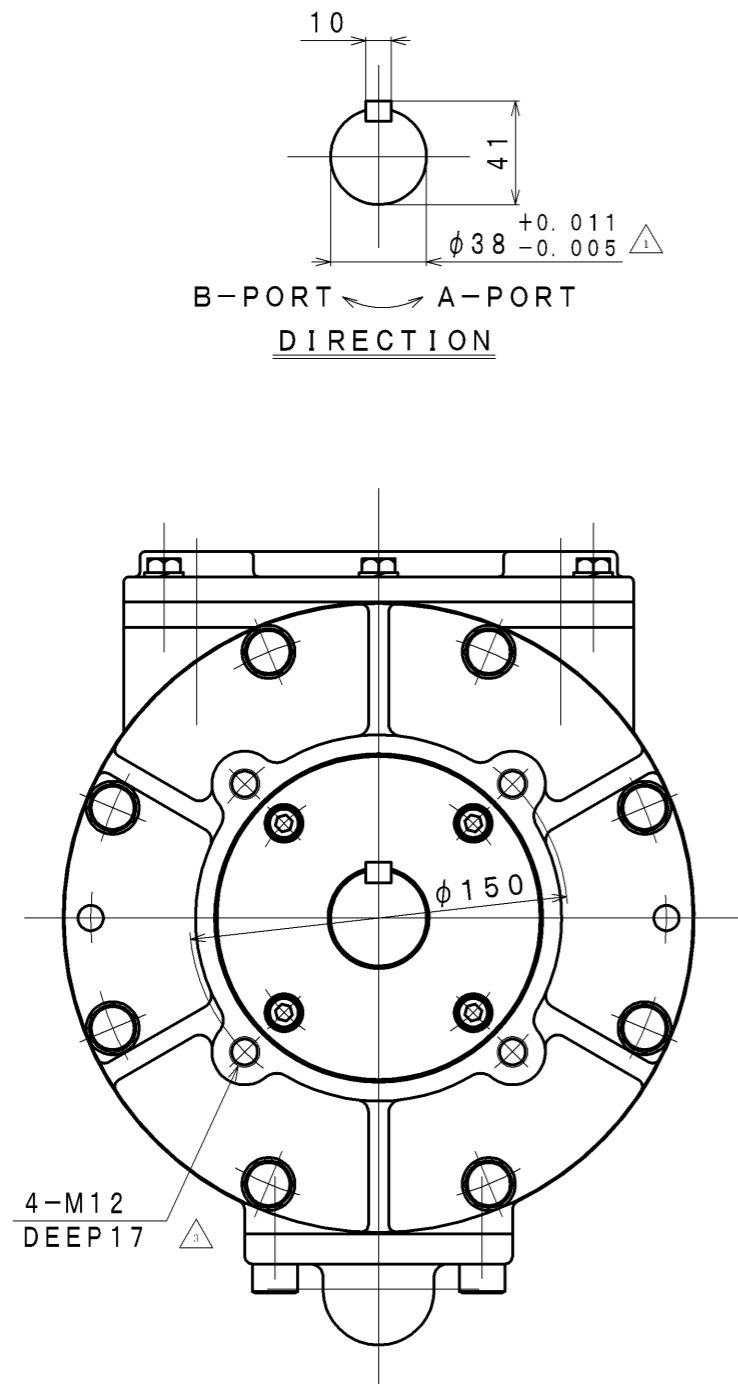

**SPECIFICATION**

AIR PRESSURE (MPa)	AT MAXIMUM OUTPUT				* ALLOWABLE SHAFT LOAD		LUBRICATING OIL	MASS (kg)
	OUTPUT (kW)	SPEED (rpm)	TORQUE (N·m)	AIR CONSUMPTION (m <sup>3</sup> /min (nor))	RADIAL (kN)	THRUST (kN)	AIR MOTOR (Line Oiler)	
0.6	8.29	1600	49.5	10.0	1.86	0.49	△ JIS K2213-1 Turbine Oil ISO VG32 (Line Oiler Dripping Quantity: 25~30 drop/min)	40.8
0.5	6.60	1400	45.0	9.0				
0.4	4.80	1200	38.2	7.4				

\*: At Mid of Shaft

APPROVED	CHECKED	REVIEWED	DRAWN	PARTICULARS	OUTLINE DRAWING	DATE	Nov. 07. 2005
M. S	K. S		R. T	MODEL	VF75-UKD1	NOTE	
					AIR MOTOR	Z05-046	△
SAN-EI SEIKI SEISAKUSYO CO., LTD.				DWG. NO.	E305-216	SCALE	1/3