

SIGN	REVISION	DATE	B Y
△1	Renewal	111031	R. T
△2	Renewal	160405	W. S

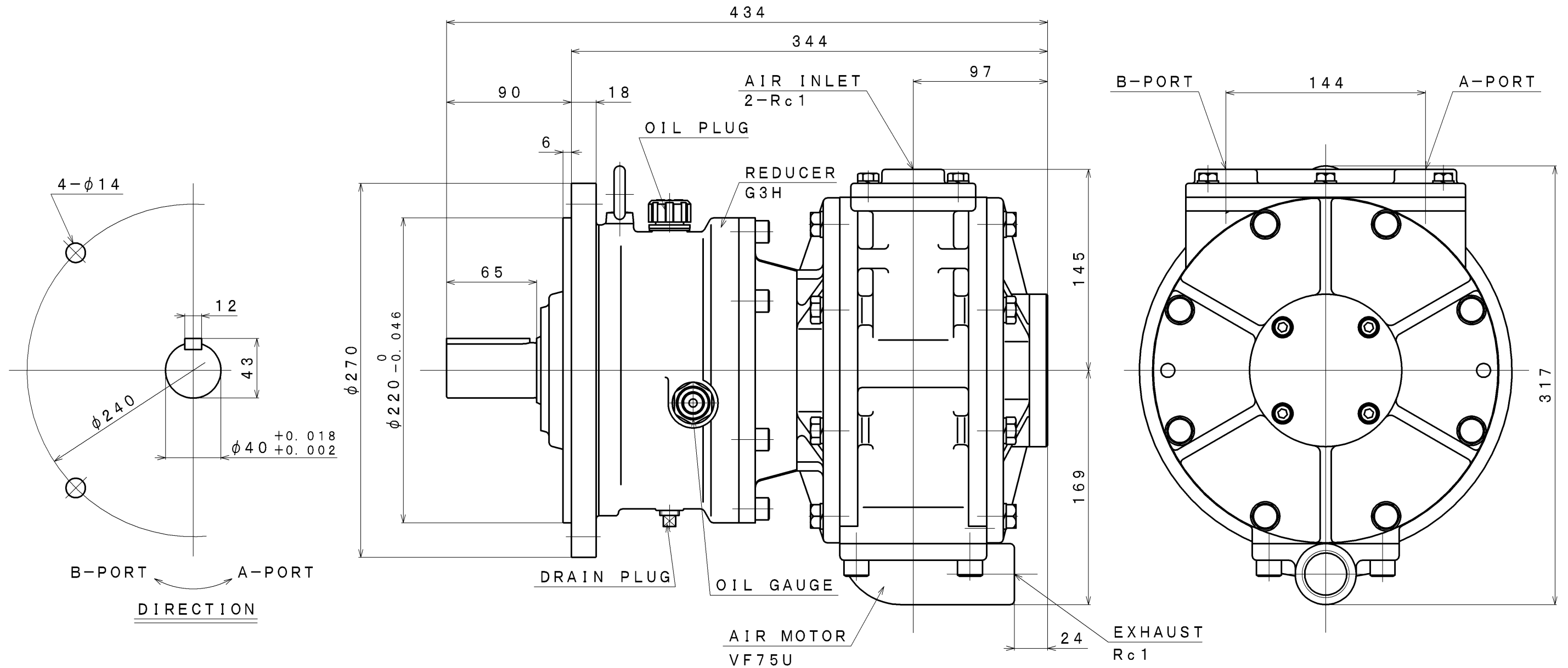

**SPECIFICATION**

AIR PRESSURE	AT MAXIMUM OUTPUT				* ALLOWABLE SHAFT LOAD		LUBRICATING OIL		MASS
	OUTPUT	SPEED	TORQUE	AIR CONSUMPTION	RADIAL	THRUST	AIR MOTOR	REDUCER	
(MPa)	(kW)	(rpm)	(N·m)	(m <sup>3</sup> /min (nor))	(kN)	(kN)	△ JIS K2213-1 Turbine Oil ISO VG32 Line Oiler Dripping Quantity: 25~30drop/min	JIS K2219 Gear Oil ISO VG220 (150cc)	(kg)
0.6	7.89	291	258.6	10.0	2.6	0.5			about 72
0.5	6.27	255	235.1	9.0					
0.4	4.56	218	199.6	7.4					

\*: At Mid of Shaft

APPROVED	CHECKED	REVIEWED	DRAWN	PARTICULARS	OUTLINE DRAWING	DATE	FEB. 16. 2010
M. M		W. S		MODEL	VF75U-G3H6F	NOTE	
					AIR MOTOR	Z06-052	
SAN-EI SEIKI SEISAKUSHO CO., LTD.					DWG. NO.	E310-121	SCALE 1/3