

SIGN	REVISION	DATE	B Y
△1	Correction, Q-395	081229	M. M
△2	Renewal	160408	W. S

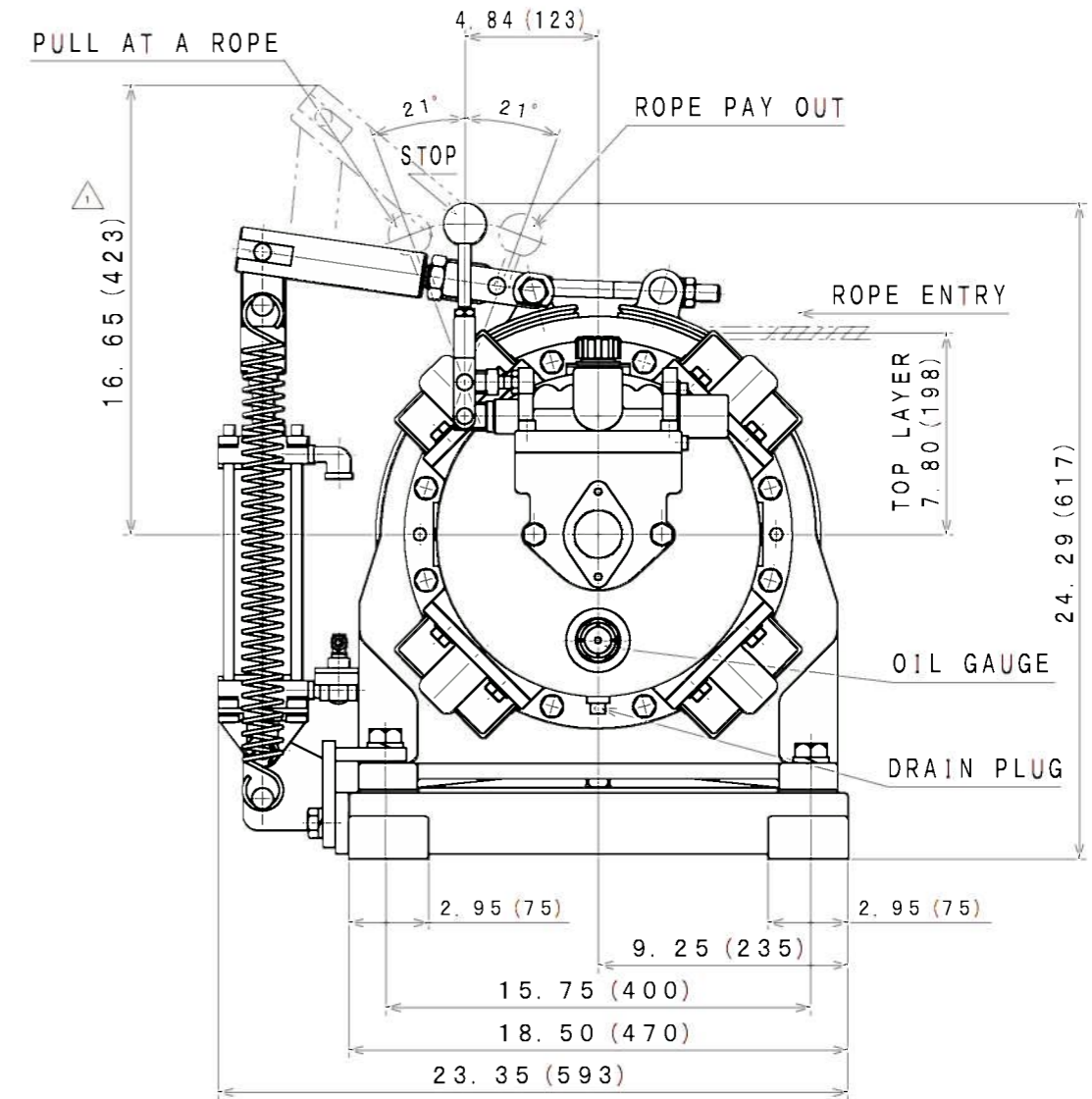
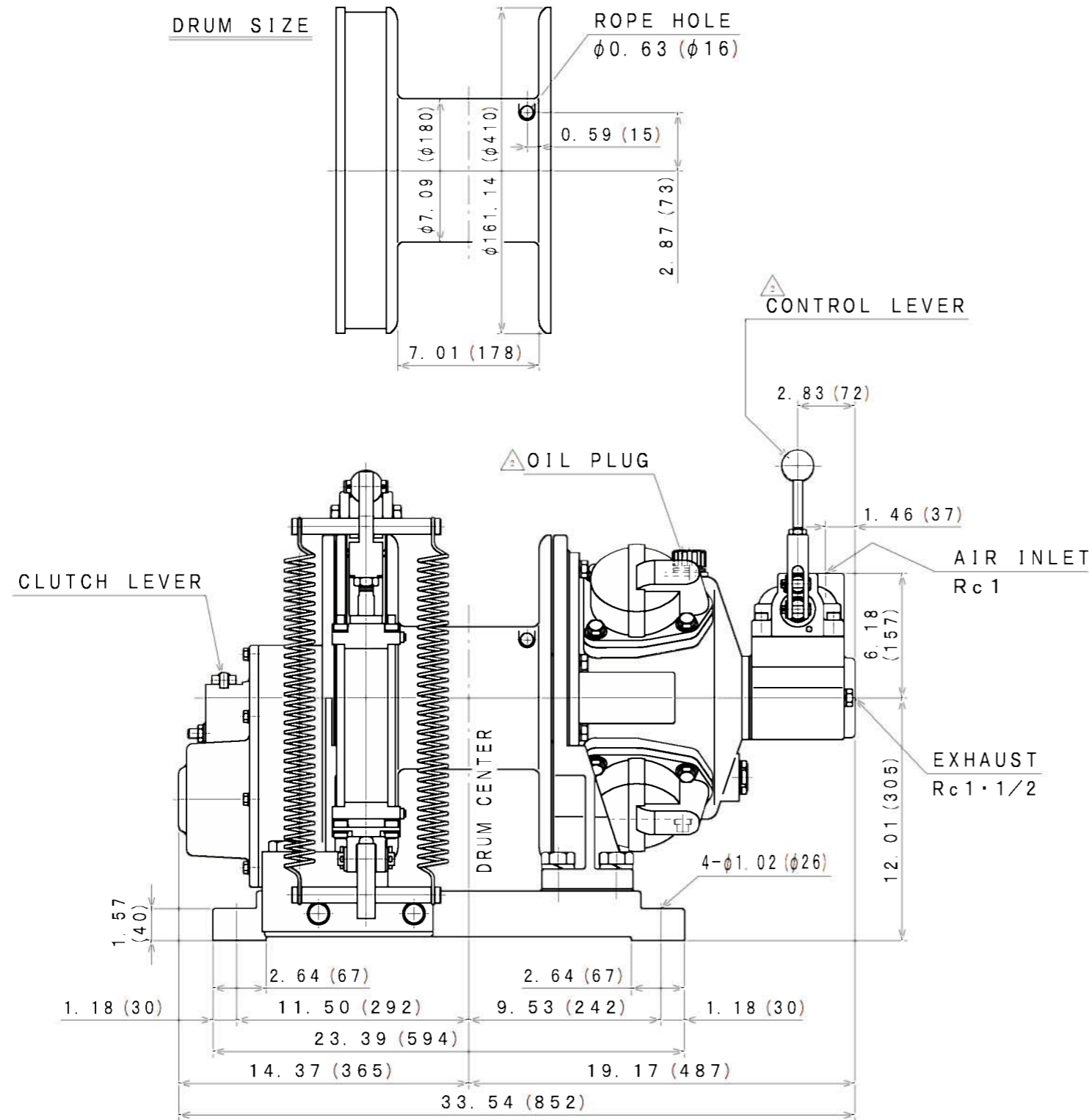

NOTE

DIMENSIONS ARE INCHES, BRACKETS () METRIC mm.

SPECIFICATIONS (at HALF DRUM)

AIR PRESSURE psi (MPa)	MOTOR POWER hp (kW)	ROPE PULL lb (kN)	ROPE SPEED fpm (m/min)	AIR CONSUMPTION cfm (m ³ /min (nor)) △	ROPE CAPACITY φ in x ft (m)	WEIGHT lb (kg)
90 (0.62)	9.6 (7.15)	4400 (20)	62 (19)	191 (5.4)	1/2 x 375 (115)	ABOUT 607 (276)

APPROVED	CHECKED	REVIEWED	DRAWN	PARTICULARS	OUTLINE DRAWING	DATE	FEB. 12, 1998
H. K	S. N		M. M	MODEL	W-20-220-SAC-AB	NOTE	
					AIR WINCH	Z97-104	
SAN-EI SEIKI SEISAKUSHO CO., LTD.					DWG. NO.	E398-002 △	SCALE 1/7