

SIGN	REVISION	DATE	B	Y
△1	Renewal	120413	M.	A.
△2	Renewal	120704	M.	A.
△3	Renewal	120719	M.	A.

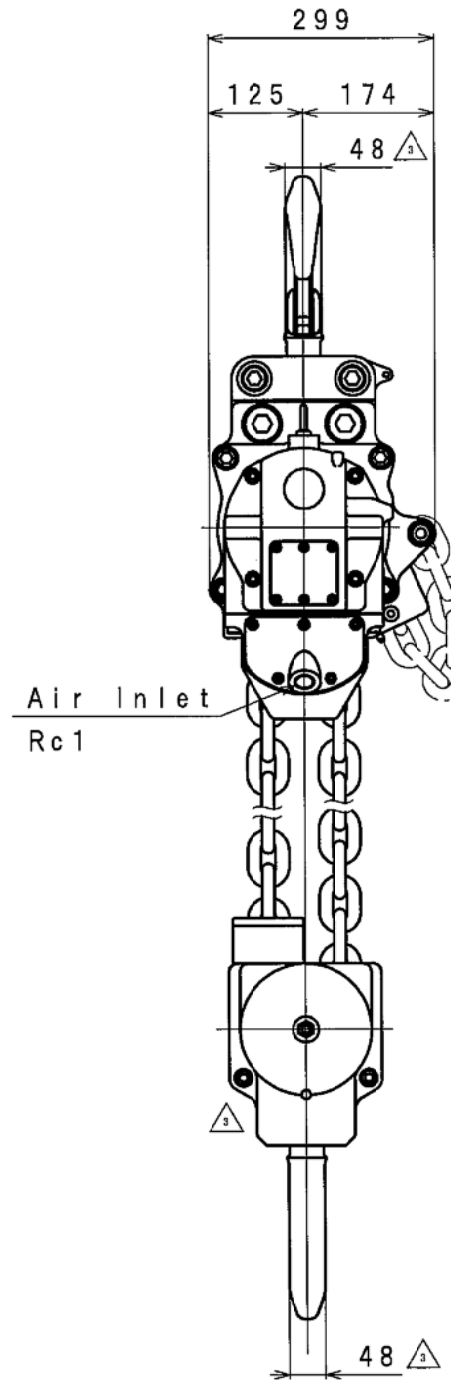
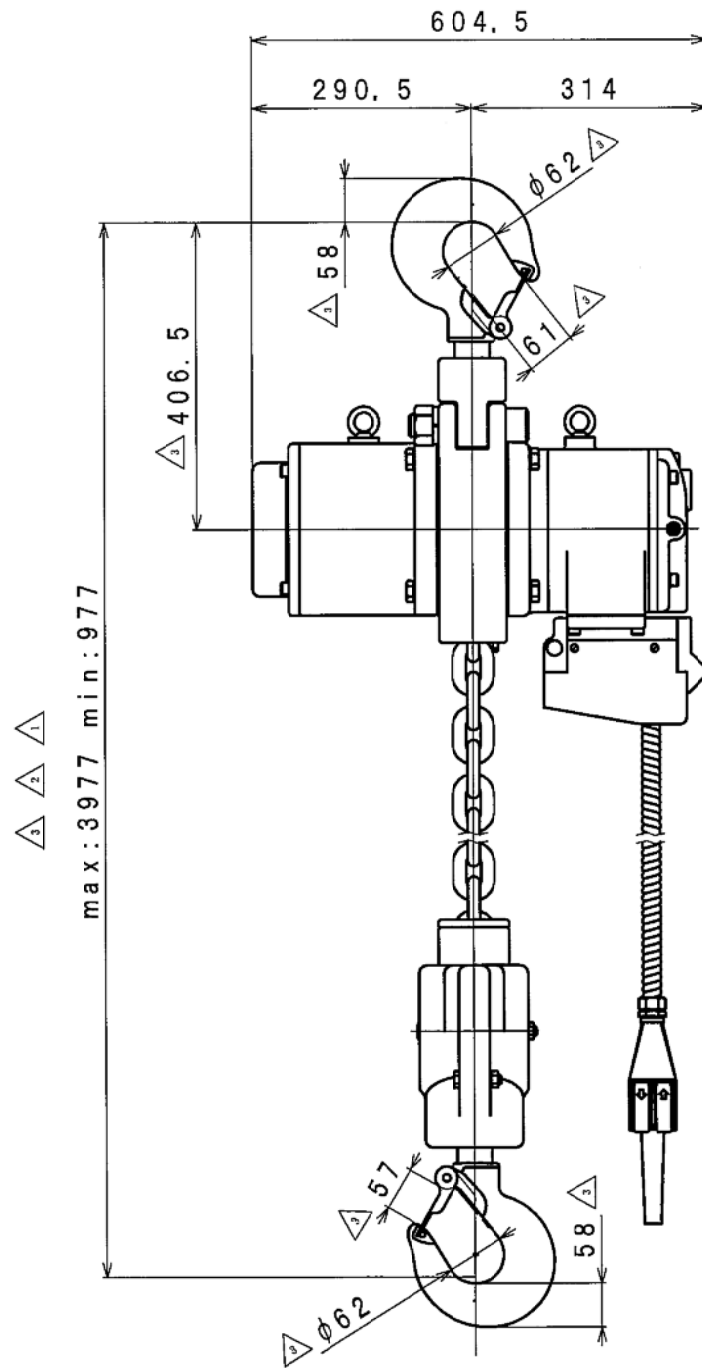

REFERENCE

SPECIFICATION

AIR PRESSURE	(MPa)	0.5
CAPACITY	(kg)	10000
LIFTING SPEED	(m/min)	1.6
AIR CONSUMPTION	(m ³ /min (nor))	about 6.2 △
LIFT	(m)	3 △
MASS	(kg)	about 260 △

APPROVED	CHECKED	REVIEWED	DRAWN	PARTICULARS	OUTLINE DRAWING	DATE	APR. 10. 2012
<i>[Signature]</i>	<i>[Signature]</i>		<i>Masakazu Abe</i>	MODEL	GLX10LP	NOTE	
SAN-EI SEIKI SEISAKUSYO CO., LTD.					DWG. NO.	E312-090 △3	SCALE 1/10