

SIGN	REVISION	DATE	BY
△	Renewal	111107	R. T
△	Renewal	160411	W. S

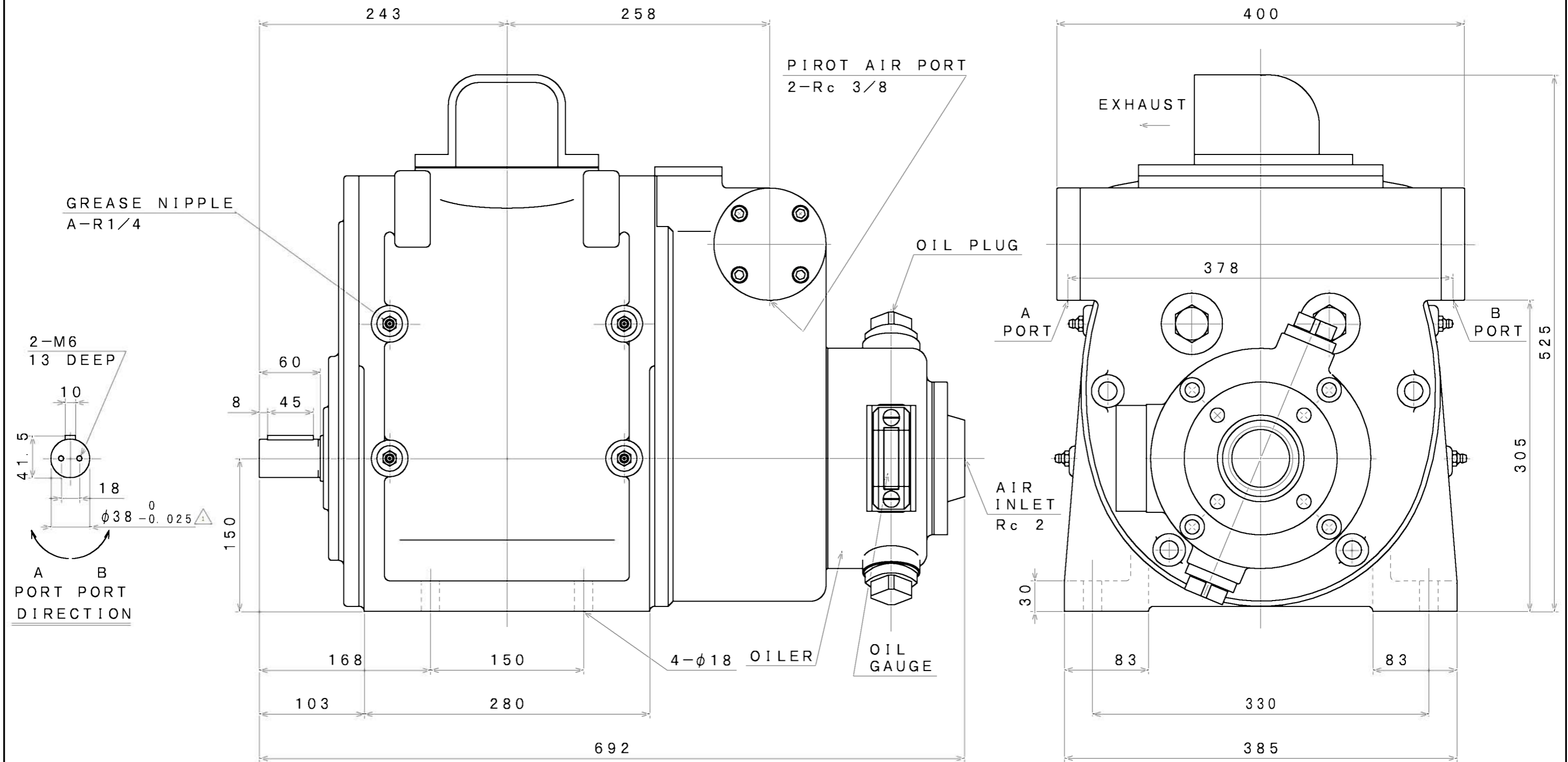

SPECIFICATION

AIR PRESSURE	AT MAXIMUM OUTPUT				OILER QUANTITY	OIL CONSUMPTION	LUBRICATING OIL		MASS
	OUTPUT	SPEED	TORQUE	AIR CONSUMPTION			OILER	GREASE NIPPLE	
(MPa)	(kW)	(rpm)	(N·m)	(m ³ /min (nor))	(cc)	(cc/hr)	△ JIS K2213-1 Turbine Oil ISO VG32~56	JIS K2220 4-2 Lithium Grease	(kg)
0.6	14.1	1500	90	16.0	1500	150~200			About 270
0.5	11.8		75	13.5					
0.4	9.4		60	10.5					

APPROVED	CHECKED	REVIEWED	DRAWN	PARTICULARS	OUTLINE DRAWING	DATE	NOV. 19. 1997
M. S	K. S		R. T	MODEL	AGM15-HBR1	NOTE	
SAN-EI SEIKI SEISAKUSHO CO., LTD.					AIR MOTOR	Z97-021	
DWG. NO. E397-301					SCALE	1/4	