

SIGN	REVISION	DATE	B Y
△1	Renewal	111101	R. T
△2	Renewal	140228	W. S

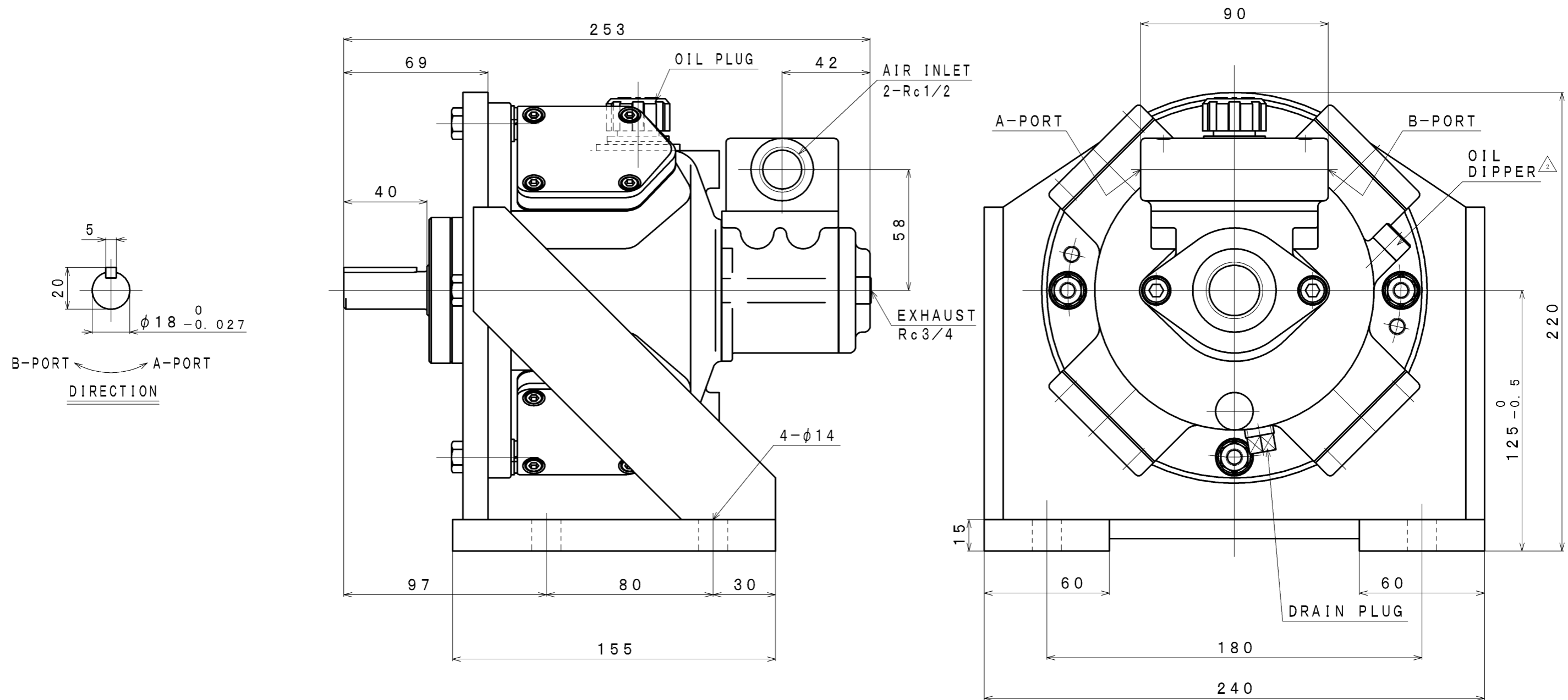

SPECIFICATION

AIR PRESSURE	AT MAXIMUM OUTPUT				※ ALLOWABLE SHAFT LOAD		LUBRICATING OIL	MASS
	OUTPUT	SPEED	TORQUE	AIR CONSUMPTION △	RADIAL	THRUST		
(MPa)	(kW)	(rpm)	(N·m)	(m ³ /min (nor))	(kN)	(kN)	△ JIS K2213-1 Turbine Oil ISO VG32 (140cc)	(kg)
0.6	0.86	1400	5.9	0.8	0.4	0.15	about 16.5	
0.5	0.64	1300	4.7	0.7				
0.4	0.49	1200	3.9	0.5				

※: At Mid of Shaft

APPROVED	CHECKED	REVIEWED	DRAWN	PARTICULARS	OUTLINE DRAWING	DATE	DEC. 14. 2009
M. M		W. S		MODEL	DM1-HBD1	NOTE	
					AIR MOTOR	Z78-083	
SAN-EI SEIKI SEISAKUSHO CO., LTD.					DWG. NO.	E309-193	SCALE 1/2