

SIGN	REVISION	DATE	B Y
△1	Renewal	111101	R. T
△2	Renewal	131007	W. S

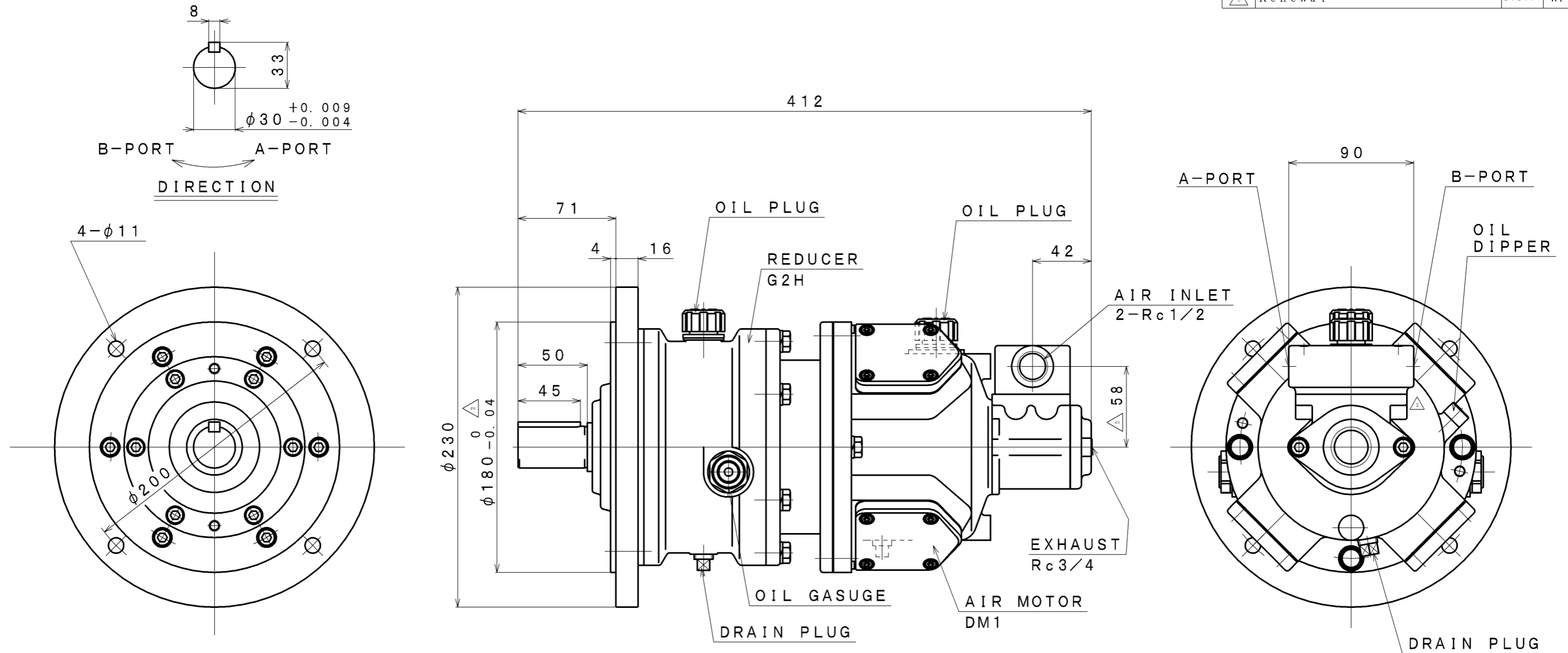

**SPECIFICATION**

AIR PRESSURE (MPa)	AT MAXIMUM OUTPUT				* ALLOWABLE SHAFT LOAD		LUBRICATING OIL		MASS (kg)
	OUTPUT (kW)	SPEED (rpm)	TORQUE (N·m)	AIR CONSUMPTION $\Delta_2$ (m <sup>3</sup> /min (nor))	RADIAL (kN)	THRUST (kN)	AIR MOTOR $\Delta_1$ JIS K2213-1 Turbine Oil ISO VG32 (140cc)	REDUCER JIS K2219 Gear Oil ISO VG220 (130cc)	
0.6	0.75	180	40.0	0.86	2.6	0.4	$\Delta_2$		about 26
0.5	0.56	160	33.6	0.72					
0.4	0.43	150	27.7	0.53					

\*:At Mid of Shaft

APPROVED	CHECKED	REVIEWED	DRAWN	PARTICULARS	OUTLINE DRAWING	DATE	JAN. 28. 2010
M. S	K. S	R. T	W. S	MODEL	DM1G2H8F	NOTE	
					AIR MOTOR	Z97-010	
SAN-EI SEIKI SEISAKUSHO CO., LTD.				DWG. NO.	E310-089	SCALE	1/3