

SIGN	REVISION	DATE	B Y
△1	Renewal	111101	R. T
△2	Correction	120222	R. T
△3	Renewal	160406	W. S

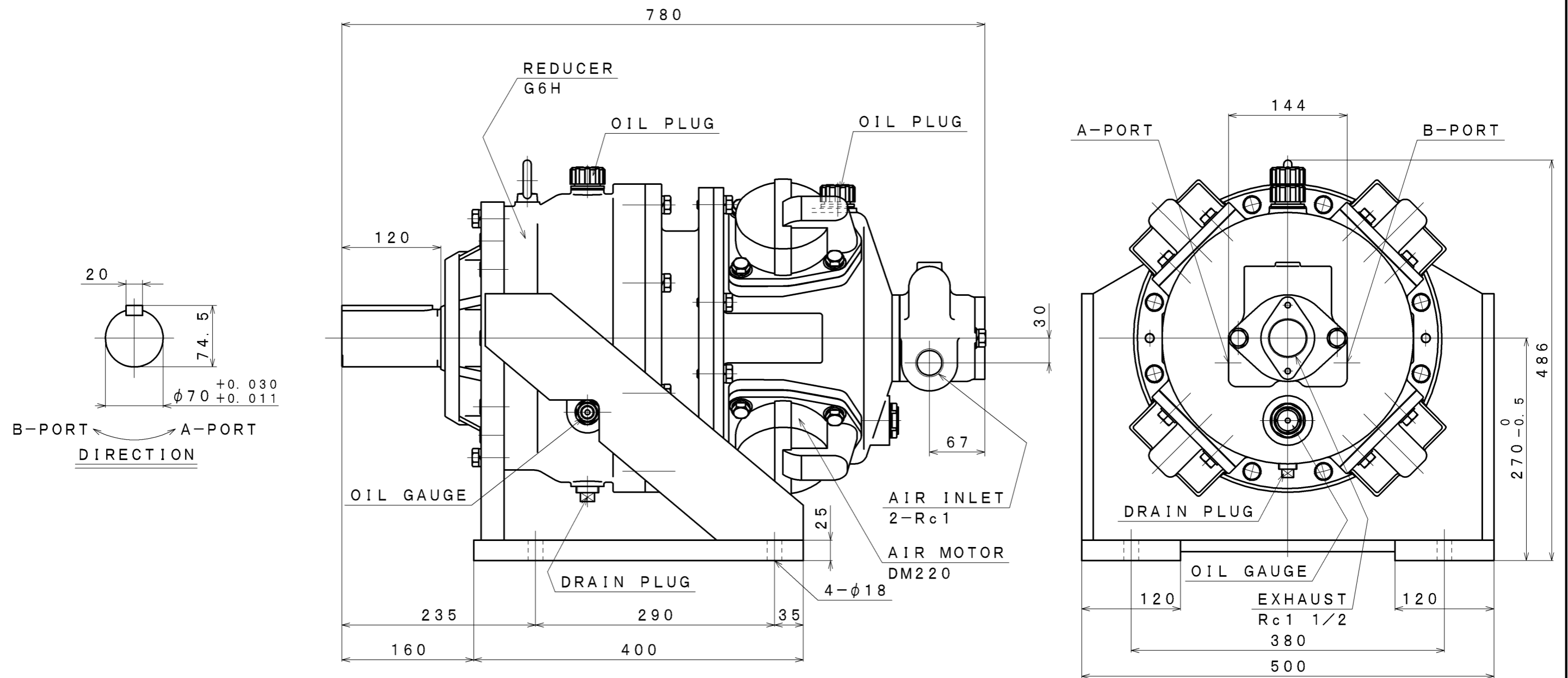

SPECIFICATION

AIR PRESSURE (MPa)	AT MAXIMUM OUTPUT				* ALLOWABLE SHAFT LOAD		LUBRICATING OIL		MASS (kg)
	OUTPUT (kW)	SPEED (rpm)	TORQUE (N·m)	AIR CONSUMPTION (m ³ /min (nor))	RADIAL (kN)	THRUST (kN)	AIR MOTOR	REDUCER	
0.6	6.68	90	709	5.4	16.5	3.0	△ JIS K2213-1 Turbine Oil	JIS K2219 Gear Oil	about 293
0.5	5.60	84	637	4.8			ISO VG32 (850cc)	ISO VG220 (1200cc)	
0.4	4.57	78	559	4.1					

*: At Mid of Shaft

APPROVED	CHECKED	REVIEWED	DRAWN	PARTICULARS	OUTLINE DRAWING	DATE	MAY. 06. 2011
M. S	K. S	R. T	W. S	MODEL	DM220G6H8B	NOTE	
SAN-EI SEIKI SEISAKUSHO CO., LTD.					DWG. NO.	E311-247	SCALE 1/5