

SIGN	REVISION	DATE	B Y
△1	Renewal	111101	R. T
△2	Correction	120222	R. T
△3	Renewal	160407	W. S

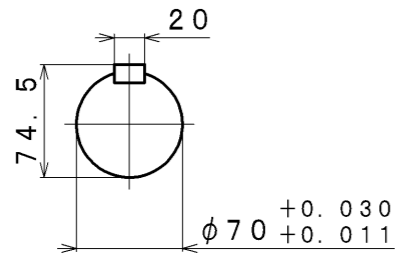

B-PORT A-PORT
DIRECTION

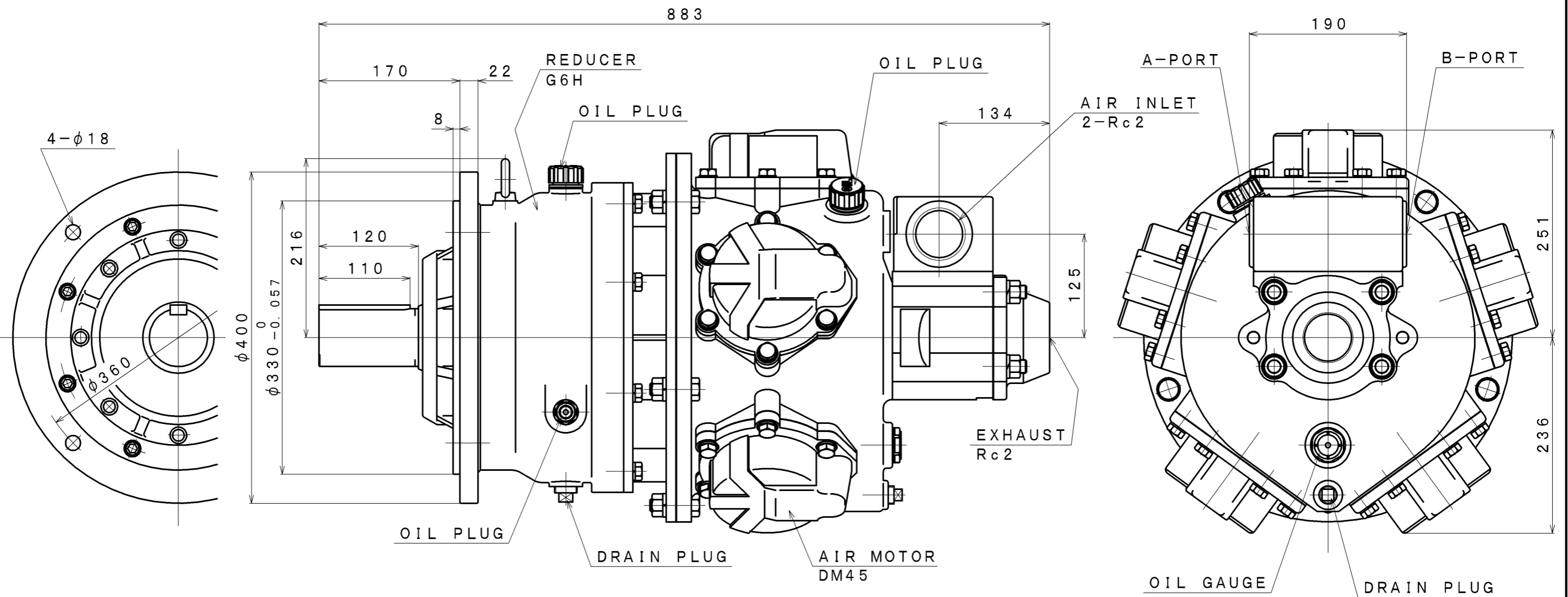

SPECIFICATION

AIR PRESSURE (MPa)	AT MAXIMUM OUTPUT				* ALLOWABLE SHAFT LOAD		LUBRICATING OIL		MASS (kg)
	OUTPUT (kW)	SPEED (rpm)	TORQUE (N·m)	AIR CONSUMPTION (m ³ /min (nor))	RADIAL (kN)	THRUST (kN)	AIR MOTOR	REDUCER	
0.6	16.9	240	671	17.0	11.5	3.0	△1 JIS K2213-1 Turbine Oil (1400cc)	JIS K2219 Gear Oil ISO VG220 (1200cc)	△2 about 350
0.5	13.5	230	560	14.0					
0.4	10.5	210	478	12.0					

*: At Mid of Shaft

APPROVED	CHECKED	REVIEWED	DRAWN	PARTICULARS	OUTLINE DRAWING	DATE	JAN. 26. 2010
M. M		W. S		MODEL	DM45G6H4F	NOTE	
					AIR MOTOR		
SAN-EI SEIKI SEISAKUSHO CO., LTD.				DWG. NO.	E310-076	SCALE	1/5