

SIGN	REVISION	DATE	B Y
△1	Renewal	100219	W. S
△2	Renewal	111028	R. T
△3	Renewal	130524	W. S

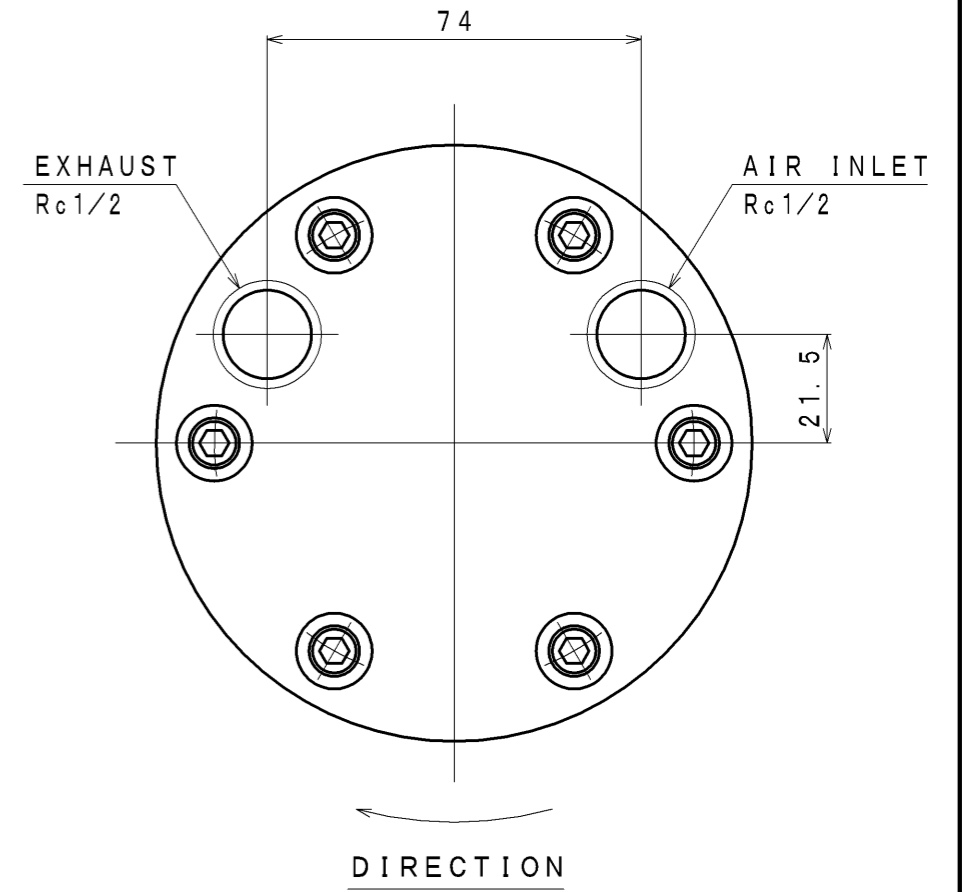
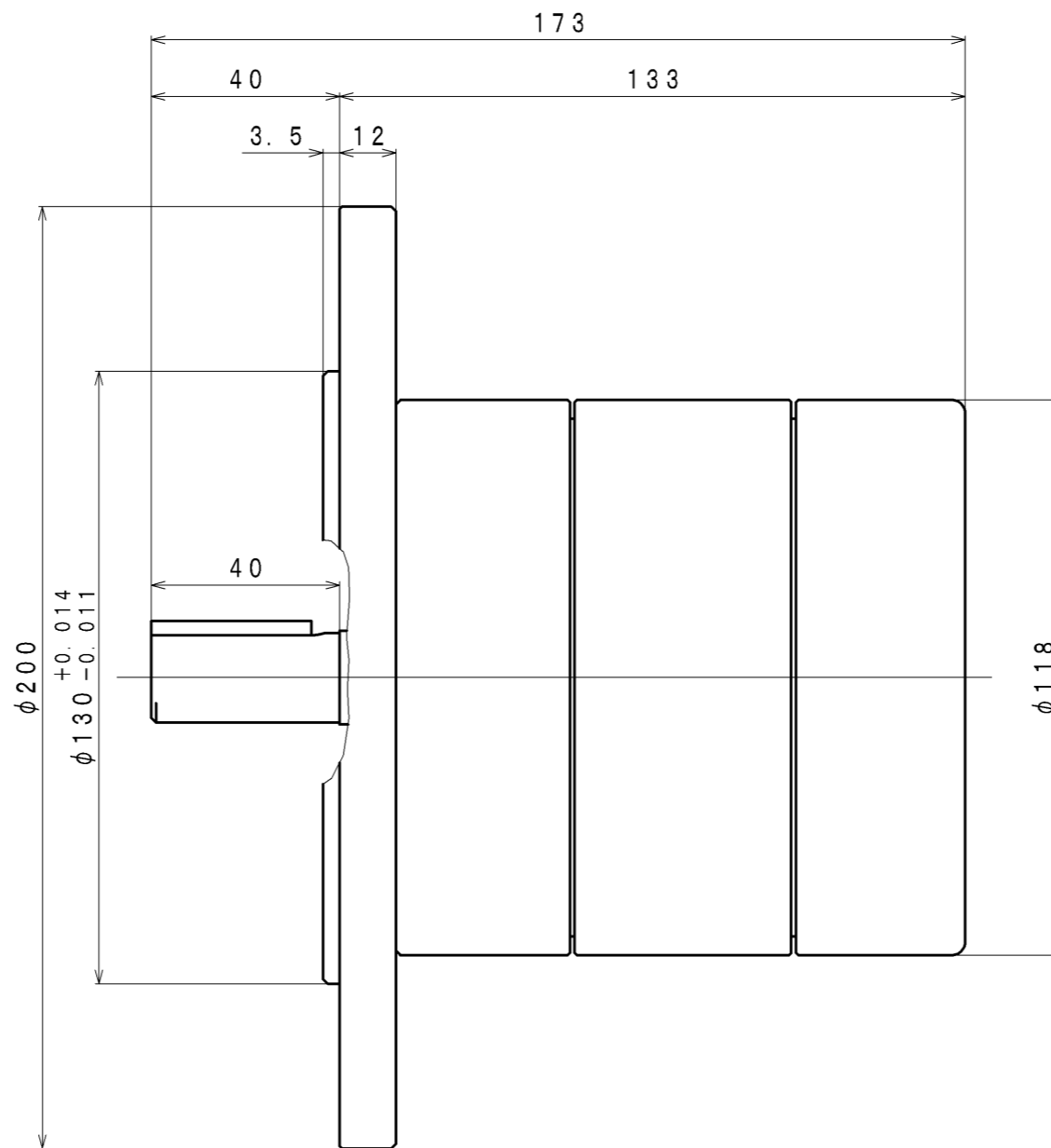
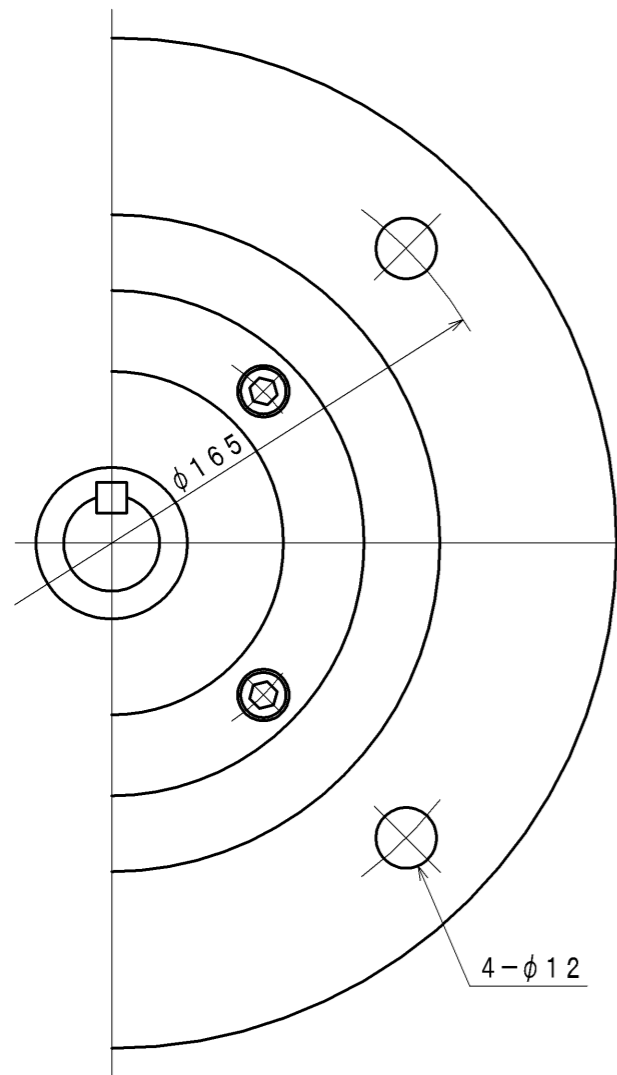
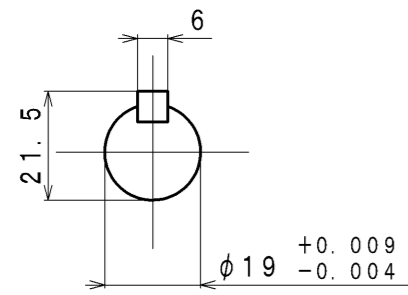

**SPECIFICATION**

AIR PRESSURE (MPa)	AT MAXIMUM OUTPUT				※ ALLOWABLE SHAFT LOAD		LUBRICATING OIL	MASS (kg)
	OUTPUT (kW)	SPEED (rpm)	TORQUE (N·m)	AIR CONSUMPTION (m <sup>3</sup> /min (nor))	RADIAL (N)	THRUST (N)	AIR MOTOR (Line Oiler) △ JIS K2213-1 Turbine Oil ISO VG32 (Line Oiler Dripping Quantity: 3~4 drop/min)	
0.6	0.90	1960	4.40	1.52	490	294		about 9.4
0.5	0.75	1800	4.00	1.30				
0.4	0.61	1620	3.60	1.08				

※: At Mid of Shaft

APPROVED	CHECKED	REVIEWED	DRAWN	PARTICULARS	OUTLINE	DATE	DEC. 19. 2008
M. M		W. S		MODEL	VA100RF	NOTE	
					AIR MOTOR	Z91-026	
SAN-EI SEIKI SEISAKUSHO CO., LTD.					DWG. NO.	E308-106	SCALE 2/3