

SIGN	REVISION	DATE	B Y
△1	Renewal	100218	W. S
△2	Renewal	111028	R. T
△3	Renewal	130524	W. S

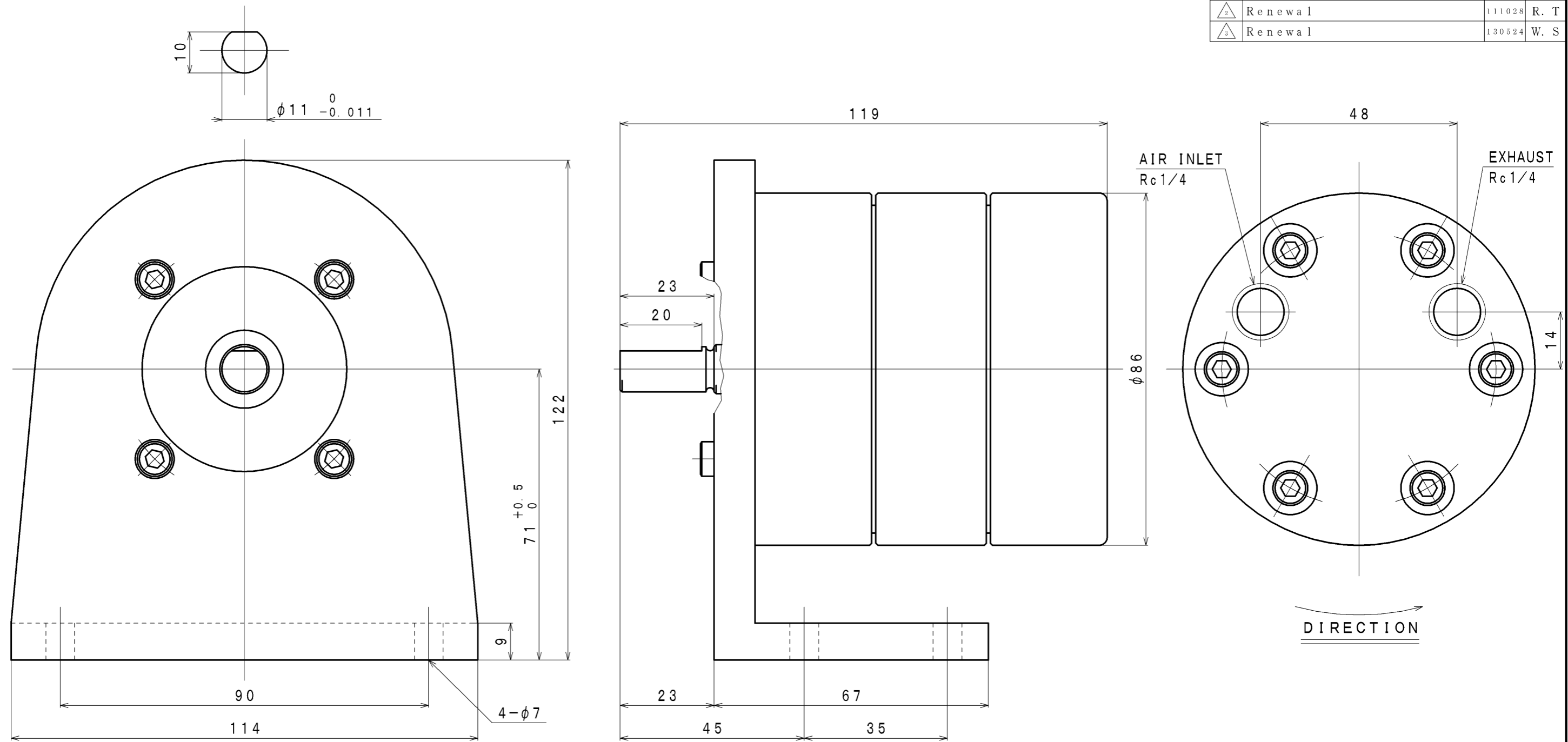

SPECIFICATION

AIR PRESSURE	AT MAXIMUM OUTPUT				* ALLOWABLE SHAFT LOAD		LUBRICATING OIL	MASS
	OUTPUT	SPEED	TORQUE	AIR CONSUMPTION \triangle	RADIAL	THRUST	AIR MOTOR (Line Oiler)	
(MPa)	(kW)	(rpm)	(N·m)	(m ³ /min (nor))	(N)	(N)	\triangle JIS K2213-1 Turbine Oil ISO VG32 (Line Oiler Dripping Quantity: 1~2 drop/min)	(kg)
0.6	0.27	1960	1.30	0.48	245	147		about 4.0
0.5	0.23	1800	1.20	0.40				
0.4	0.19	1620	1.10	0.33				

*: At Mid of Shaft

APPROVED	CHECKED	REVIEWED	DRAWN	PARTICULARS	OUTLINE	DATE	DEC. 19. 2008
M. M		W. S		MODEL	VA30LB	NOTE	
					AIR MOTOR	Z91-024	
SAN-EI SEIKI SEISAKUSHO CO., LTD.					DWG. NO.	E308-111 $\triangle 3$	SCALE 1/1