

SIGN	REVISION	DATE	B Y
△1	Renewal	100301	W. S
△2	Correction	100910	M. S
△3	Renewal	111028	R. T
△4	Renewal	130523	W. S

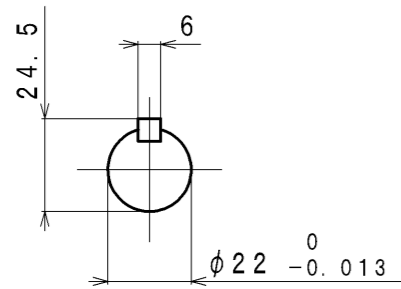

DIRECTION

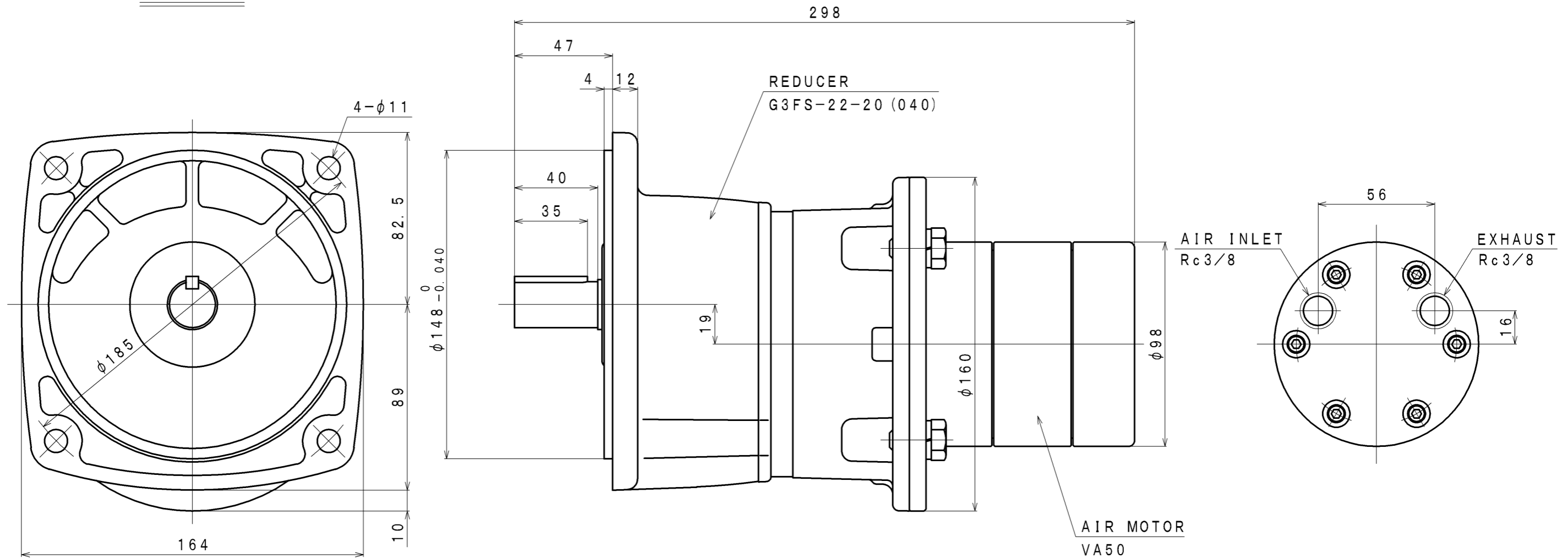

SPECIFICATION

AIR PRESSURE (MPa)	AT MAXIMUM OUTPUT				※ ALLOWABLE SHAFT LOAD		LUBRICATING OIL AIR MOTOR (Line Oiler)	MASS (kg)
	OUTPUT (kW)	SPEED (rpm)	TORQUE (N·m)	AIR CONSUMPTION (m <sup>3</sup> /min (nor))	RADIAL (N)	THRUST (N)		
0.6	0.39	98	38.0	0.79	1373	686	△ JIS K2213-1 Turbine Oil ISO VG32 (Line Oiler Dripping Quantity: 2~3 drop/min)	△ about 10.6
0.5	0.32	90	34.2	0.68				
0.4	0.25	81	30.0	0.56				

※: At Mid of Shaft

APPROVED	CHECKED	REVIEWED	DRAWN	PARTICULARS	OUTLINE DRAWING	DATE	JAN. 26. 2009
M. M		W. S		MODEL	VA50L-F020	NOTE	
					AIR MOTOR	Z96-092	
SAN-EI SEIKI SEISAKUSHO CO., LTD.					DWG. NO.	E308-231	SCALE 1/2