

SIGN	REVISION	DATE	B Y
△1	Renewal	100219	W. S
△2	Renewal	111028	R. T
△3	Renewal	130524	W. S

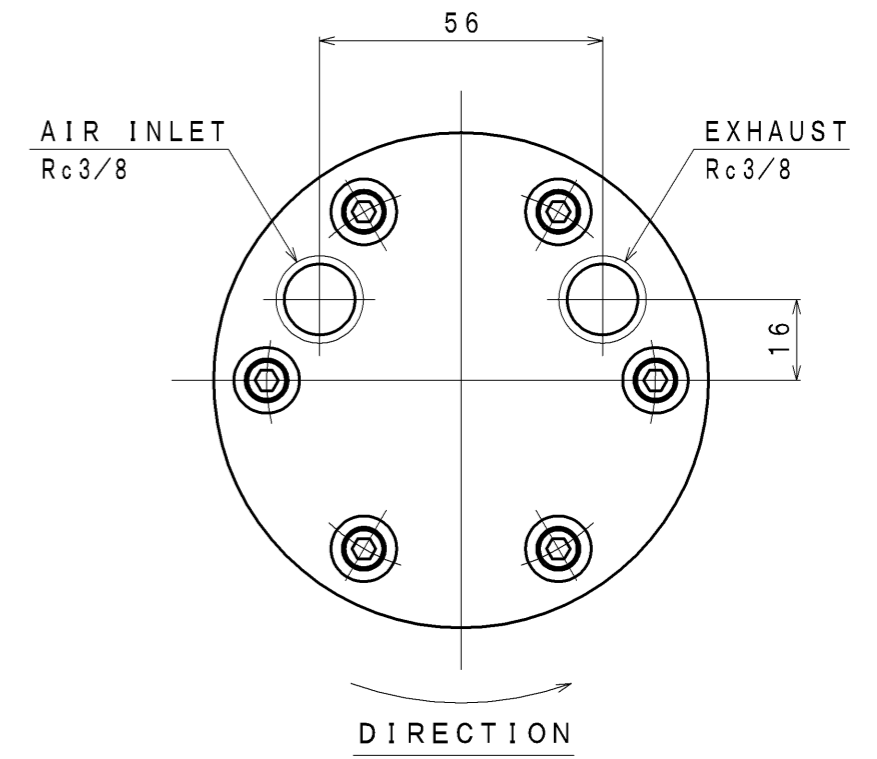
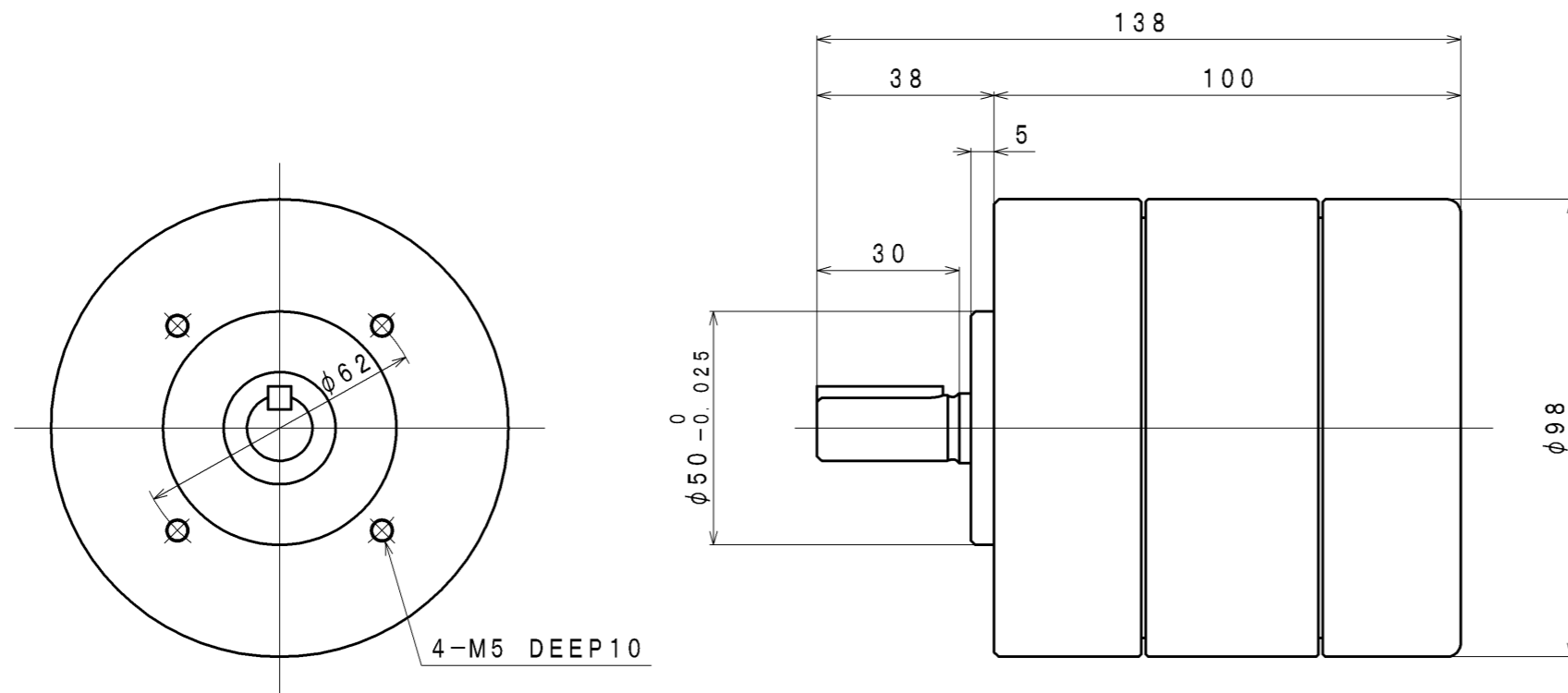
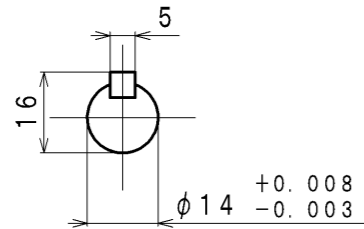

SPECIFICATION

AIR PRESSURE	AT MAXIMUM OUTPUT				※ ALLOWABLE SHAFT LOAD		LUBRICATING OIL	MASS
	OUTPUT	SPEED	TORQUE	AIR CONSUMPTION	RADIAL	THRUST	AIR MOTOR (Line Oiler)	
(MPa)	(kW)	(rpm)	(N·m)	(m ³ /min (nor))	(N)	(N)	△2 JIS K2213-1 Turbine Oil ISO VG32 (Line Oiler Dripping Quantity: 2~3 drop/min)	(kg)
0.6	0.45	1960	2.20	0.79	392	245		about 3.8
0.5	0.38	1800	2.00	0.68				
0.4	0.31	1620	1.80	0.56				

※: At Mid of Shaft

APPROVED	CHECKED	REVIEWED	DRAWN	PARTICULARS	OUTLINE	DATE	DEC. 19. 2008
M. M		W. S		MODEL	VA50LS	NOTE	
					AIR MOTOR	Z91-025	
SAN-EI SEIKI SEISAKUSHO CO., LTD.					DWG. NO.	E308-097	SCALE
						△3	2/3