

SIGN	REVISION	DATE	B Y
△1	Renewal	111031	R. T
△2	Renewal, Correction	160404	W. S

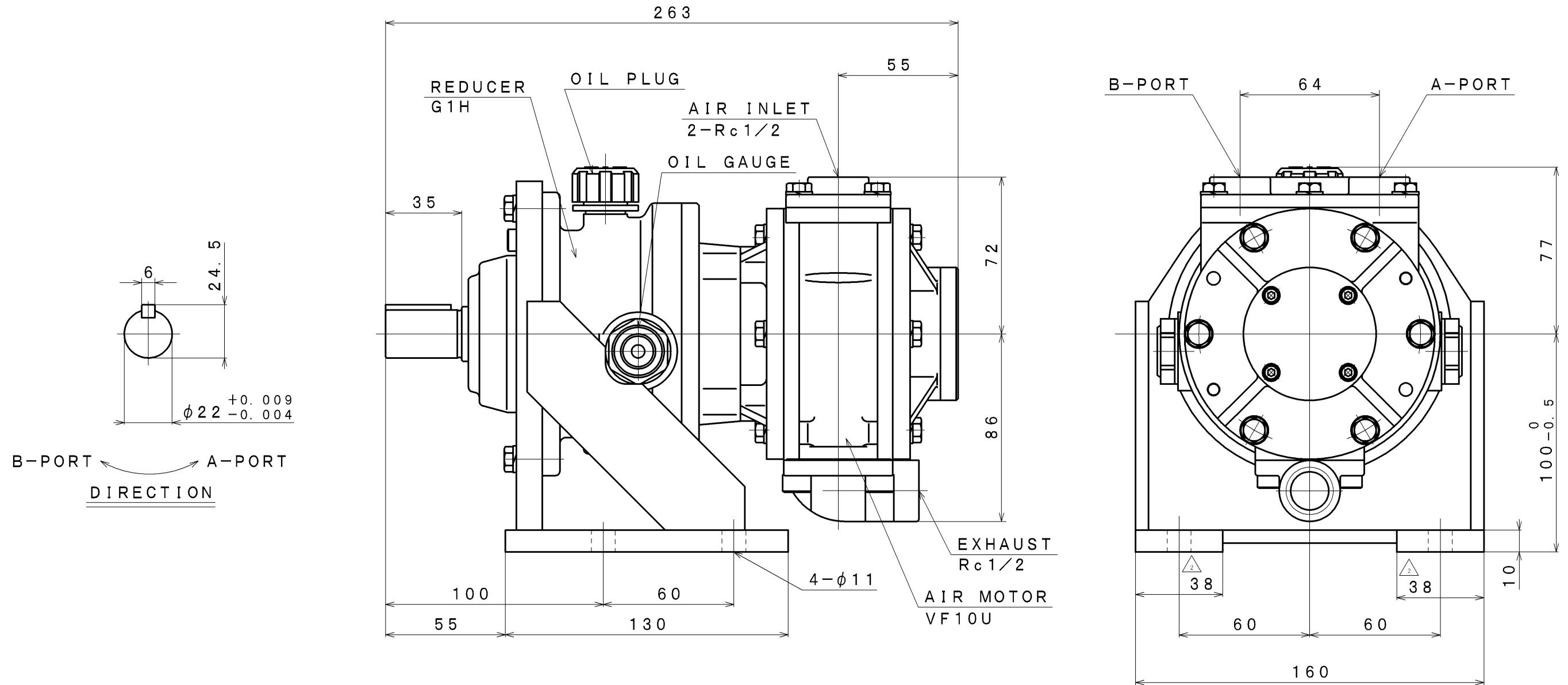

SPECIFICATION

AIR PRESSURE (MPa)	AT MAXIMUM OUTPUT				* ALLOWABLE SHAFT LOAD		LUBRICATING OIL		MASS (kg)
	OUTPUT (kW)	SPEED (rpm)	TORQUE (N·m)	AIR CONSUMPTION (m ³ /min (nor))	RADIAL (kN)	THRUST (kN)	AIR MOTOR	REDUCER	
0.6	1.03	361	27.2	1.7	1.0	0.2	JIS K2213-1 Turbine Oil ISO VG32 Line Oiler Dripping Quantity:4~5 drop/min	JIS K2219 Gear Oil ISO VG220 (60cc)	about 13.6
0.5	0.87	335	24.7	1.5					
0.4	0.67	310	20.6	1.2					

*:At Mid of Shaft

APPROVED	CHECKED	REVIEWED	DRAWN	PARTICULARS	OUTLINE DRAWING	DATE	FEB. 12. 2010
M. M		W. S		MODEL	VF10U-G1H8B	NOTE	
					AIR MOTOR	Z06-045	
SAN-EI SEIKI SEISAKUSHO CO., LTD.					DWG. NO.	E310-103	SCALE 1/2