

SIGN	REVISION	DATE	B Y
△1	Renewal	111031	R. T
△2	Renewal	160404	W. S

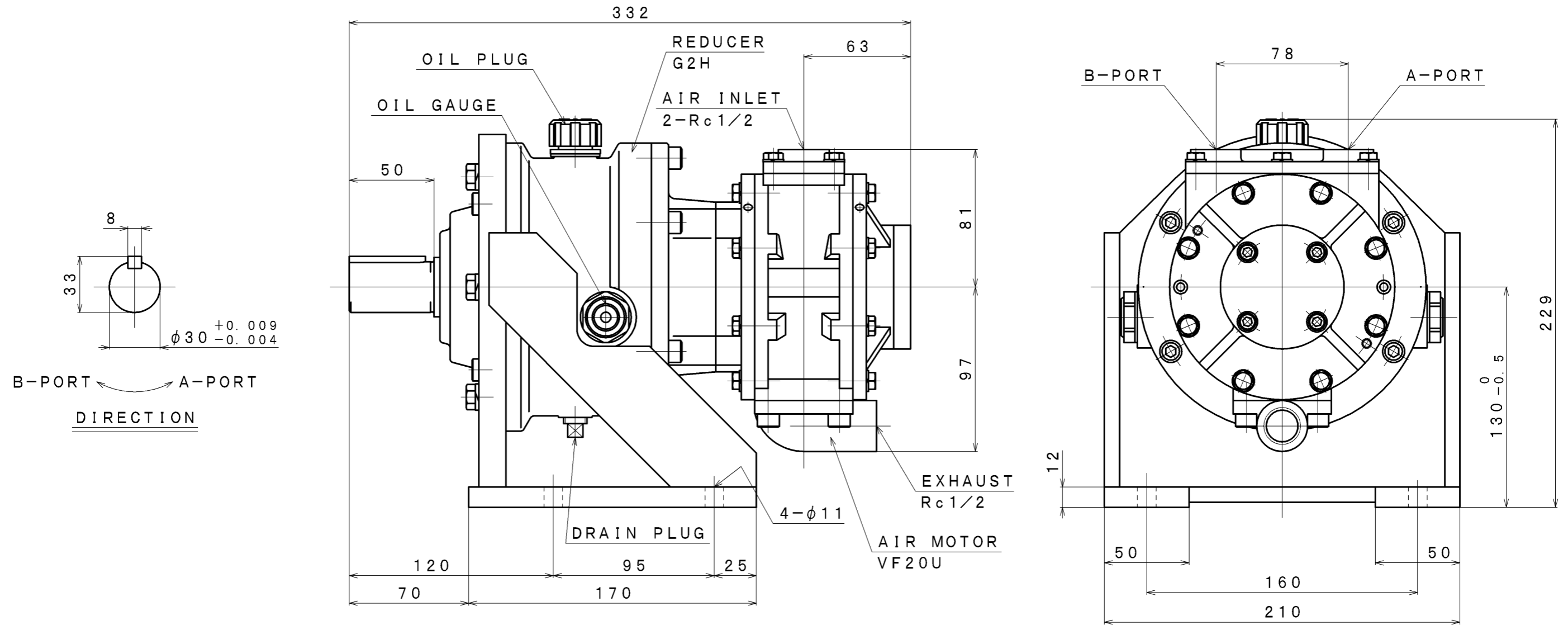

SPECIFICATION

AIR PRESSURE	AT MAXIMUM OUTPUT				※ ALLOWABLE SHAFT LOAD		LUBRICATING OIL		MASS
	OUTPUT	SPEED	TORQUE	AIR CONSUMPTION	RADIAL	THRUST	AIR MOTOR	REDUCER	
(MPa)	(kW)	(rpm)	(N·m)	(m ³ /min (nor))	(kN)	(kN)	△ JIS K2213-1 Turbine Oil ISO VG32 Line Oiler Dripping Quantity: 7~8 drop/min	JIS K2219 Gear Oil ISO VG220 (130cc)	(kg)
0.6	1.94	726	25.5	2.5	1.5	0.4			about 28
0.5	1.62	668	23.2	2.1					
0.4	1.25	610	19.6	1.8					

※: At Mid of Shaft

APPROVED	CHECKED	REVIEWED	DRAWN	PARTICULARS	OUTLINE DRAWING	DATE	FEB. 12. 2010
M. M		W. S		MODEL	VF20U-G2H4B	NOTE	
					AIR MOTOR	Z06-047	
SAN-EI SEIKI SEISAKUSHO CO., LTD.					DWG. NO.	E310-107	SCALE 2/5