

| SIGN | REVISION | DATE   | B Y  |
|------|----------|--------|------|
| △1   | Renewal  | 111031 | R. T |
| △2   | Renewal  | 160404 | W. S |

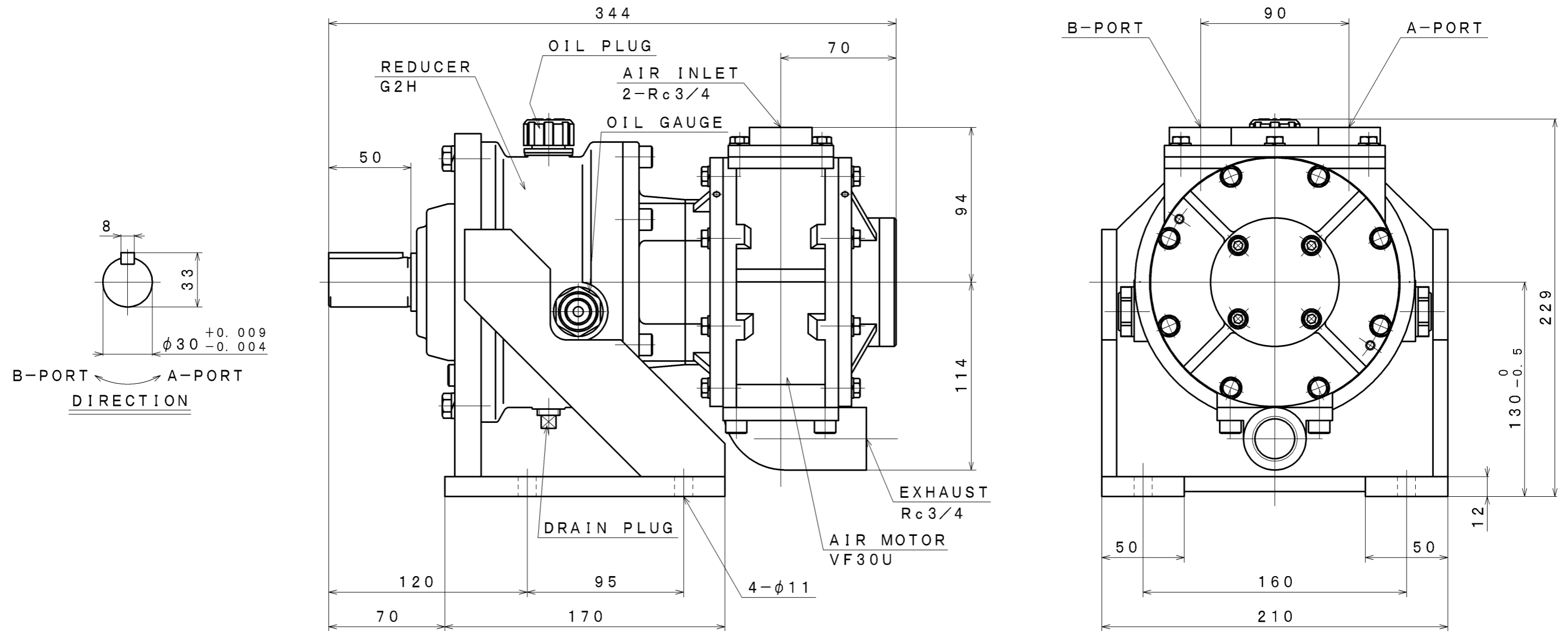

**SPECIFICATION**

| AIR PRESSURE | AT MAXIMUM OUTPUT |       |        |                             | ※ ALLOWABLE SHAFT LOAD |        | LUBRICATING OIL  |   | MASS     |
|--------------|-------------------|-------|--------|-----------------------------|------------------------|--------|--|---|----------|
|              | OUTPUT            | SPEED | TORQUE | AIR CONSUMPTION             | RADIAL                 | THRUST | AIR MOTOR  | REDUCER                                       |          |
| (MPa)        | (kW)              | (rpm) | (N·m)  | (m <sup>3</sup> /min (nor)) | (kN)                   | (kN)   | △ JIS K2213-1<br>Turbine Oil<br>ISO VG32<br>Line Oiler Dripping<br>Quantity: 10~12drop/min | JIS K2219<br>Gear Oil<br>ISO VG220<br>(130cc) | (kg)     |
| 0.6          | 2.41              | 284   | 81.0   | 3.1                         | 2.1                    | 0.5    |  |   | about 33 |
| 0.5          | 1.99              | 258   | 73.6   | 2.6                         |                        |        |  |   |          |
| 0.4          | 1.52              | 232   | 62.6   | 2.0                         |                        |        |  |   |          |

※: At Mid of Shaft

| APPROVED                          | CHECKED | REVIEWED | DRAWN | PARTICULARS | OUTLINE DRAWING | DATE     | FEB. 15. 2010 |
|-----------------------------------|---------|----------|-------|-------------|-----------------|----------|---------------|
| M. M                              |         | W. S     |       | MODEL       | VF30U-G2H8B     | NOTE     |               |
|                                   |         |          |       |             | AIR MOTOR       | Z06-049  |               |
| SAN-EI SEIKI SEISAKUSHO CO., LTD. |         |          |       |             | DWG. NO.        | E310-115 | SCALE 2/5     |